

- > Port size: 1 ... 3" (ISO G)
- > 2/2-way valves
- > Pulse Valve used for controlling the compressed air of Dust removal systems and many other applicaions
- > High Flow rate
- > Functional Compact Design
- > The key components adopts advance material
- > Pneumatic Control Type and Solenoid control type Available

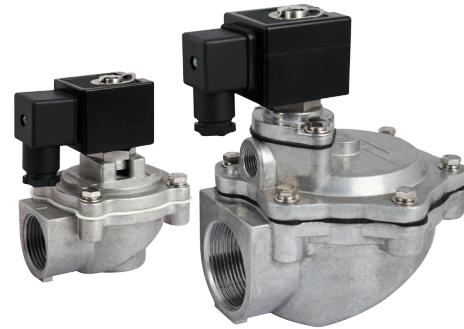

Technical features

Medium:

Compressed air

Switching function:

Normally Closed

Operating pressure:

1 ... 8 bar (0 ... 116 psi)

Relative Humidity:

<85%

Orifice:

See table

Port size:

G1, G1 1/2, G2, G2 1/2, G3

Mounting position:

Optional, preferably with solenoid vertical on top

Flow direction:

Determined

Ambient/Media temperature:

Ambient:

-20 ... +65°C (-4 ... +149°F)

Media:

-20 ... +80°C (-4 ... +176°F)

Depending on solenoid system

Air supply must be dry enough to avoid ice formation at temperatures below +2°C (+35°F).

Materials:

Body: Aluminum

Diaphragm: TPU, NBR and FKM

2/2 Way Valves with temperature -20 ... +80°C, Housing: Aluminum

Symbol	Function	Port size	Orifice (mm)	Operating pressure (bar)	Seal material	Drawing No.	Model
	2/2 NC	G1	25	1 ... 8	TPU	1	VID*2500.6201.****
	2/2 NC	G1 1/2	40	1 ... 8	NBR	2	VID*4000.6201.****
	2/2 NC	G2	50	1 ... 8	NBR	3	VID*5000.6201.****
	2/2 NC	G2 1/2	62	1 ... 8	NBR	4	VID*6200.6201.****
	2/2 NC	G3	76	1 ... 8	NBR	5	VID*7600.6201.****

*1) When ordering, please indicate solenoid, voltage and current (frequency).

Option selector

VID*****.*****.*****

<p>Material - Valve body Substitute</p> <p>Tank mount valve (G1 1/2 ... 3) A</p> <p>Right angle, indirectly solenoid actuated (G1 ... 2 1/2) B</p>	<p>Voltage Substitute</p> <p>24 V d.c. 02400</p> <p>110 V a.c., 50 Hz 11050</p> <p>220 V a.c., 50 Hz 22050</p>
<p>Port size Substitute</p> <p>G1 25</p> <p>G1 1/2 40</p> <p>G2 50</p> <p>G2 1/2 62</p> <p>G3 76</p>	<p>Coil protection Substitute</p> <p>Standard (G1", B Type) 6201</p> <p>Standard (G1 1/2" ... G2 1/2", B Type) 6202</p> <p>Standard (G1 1/2"... G3", A Type) 6204</p>
<p>Version Substitute</p> <p>TPU (G1) 00</p> <p>NBR (G1 1/2 ... 3) 00</p> <p>FKM (G1 1/2 ... 3) 60</p>	<p>*2) A Valve Type please contact Engineering Department</p>

Solenoids, standard voltages

Power consumption			Coil protection class IP	Temperature Ambient/Media (°C)	Solenoid Electrical connection	Weight (kg)
24 V d.c. (W)	110 V a.c. (VA)	220 V a.c. (VA)				
21	24	24	IP 65 (with connector)	Ambient: -20 ... +60 Fluid: -20 ... +80	DIN43650A	VIDB25** .6201.*****
18	28	28	IP 65 (with connector)	Ambient: -20 ... +60 Fluid: -20 ... +80	DIN43650A	VIDB40** .6202.***** VIDB50** .6202.***** VIDB62** .6202.*****
20	25	25	IP 65 (with connector)	Ambient: -20 ... +60 Fluid: -20 ... +80	DIN43650A	VIDA40** .6204.***** VIDA50** .6204.***** VIDA62** .6204.***** VIDA76** .6204.*****

Standard voltages (±10%) 24 V d.c., 110 V a.c., 220 V a.c., other voltages on request. Connector DIN43650A TYPE. 100% duty cycle.
Coil Insulation Class - H for 6201 & 6202 type & F for 6204 type
Temperatures mentioned refer to coils only.
Pneumatically operated valves are available on request.
For other power coils please contact Engineering Team.

Section View

Valves
for VIDB***.*****.***** version only**

G1

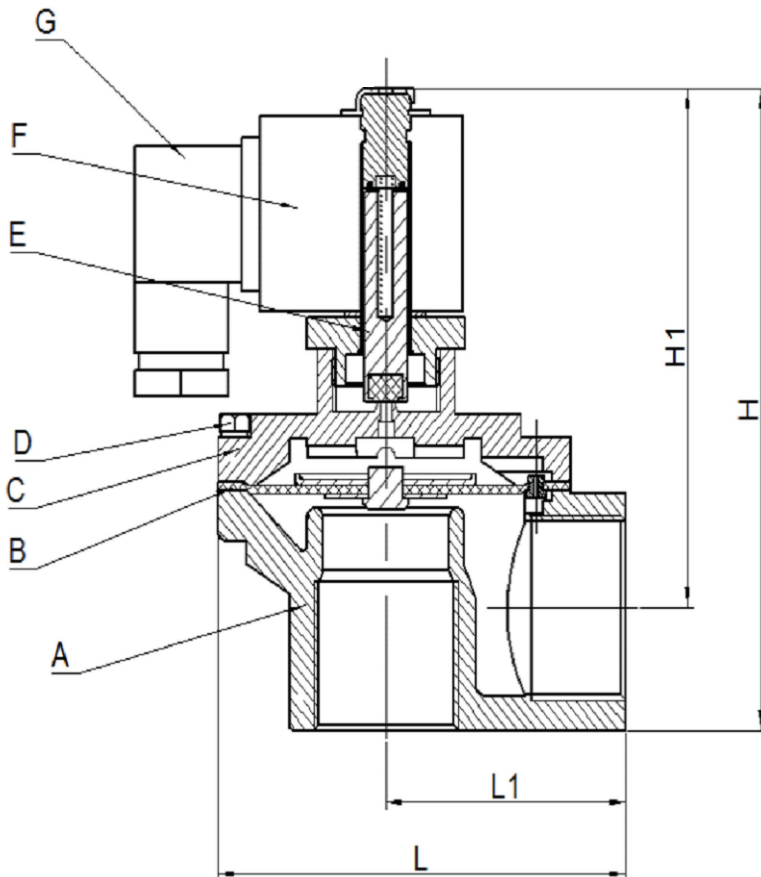

No.	Description
A	Valve body
*B	Diaphragm
C	Valve cover
D	Allen head screw
E	Armature set
*F	coil
*G	Electrical connector
*P	Pressure spring

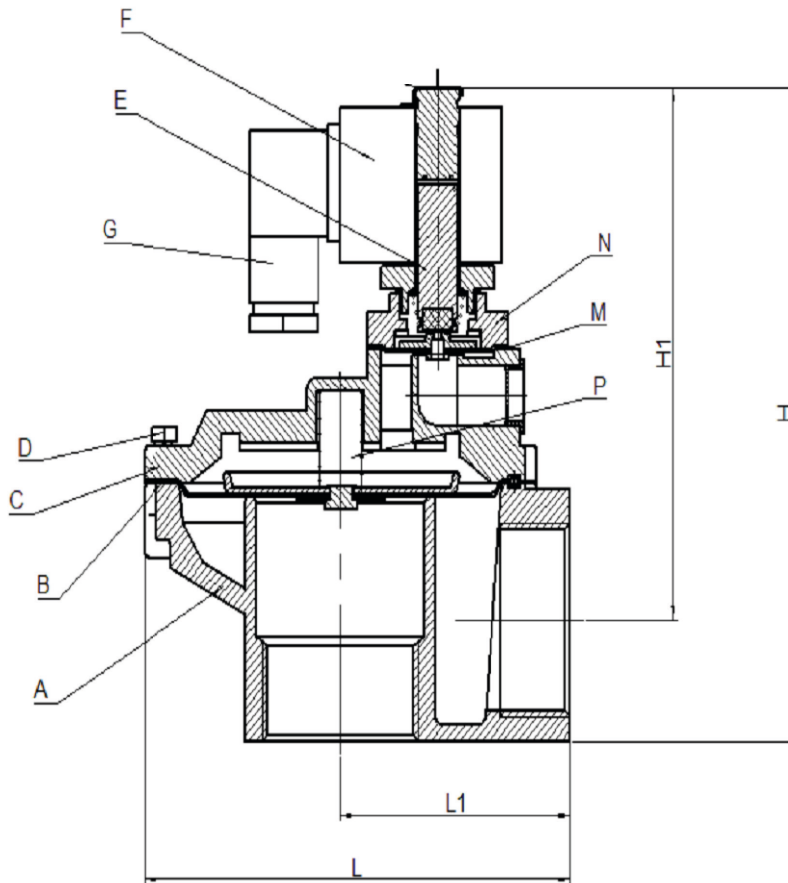
Section View
Valves
for VIDB***.*****.***** version only**
G1 1/2 ... 2 1/2

No.	Description
A	Valve body
*B	Diaphragm
C	Valve cover
D	Allen head screw
E	Armature set
*F	coil
*G	Electrical connector
*M	Diaphragm
N	Valve cover
*P	Pressure spring

*) These are spare parts available, please contact IMI Norgren for more details

Port size	H	H1	L	L1	Model
G1	112	91	88	53	VIDB2500.6201.****
G1 1/2	162	132	131,5	71	VIDB4000.6201.****
G2	208	165	167,5	95	VIDB5000.6201.****
G2 1/2	208	165	167,5	95	VIDB6200.6201.****

Warning

These products are intended for use in industrial compressed air and fluid systems only. Do not use these products where pressures and temperatures can exceed those listed under »**Technical features/data**«. Before using these products with fluids other than those specified, for non-industrial applications, life-support systems, or other applications not within published specifications, consult IMI Precision Engineering, IMI Norgren Herion Pvt. Ltd.

Through misuse, age, or malfunction, components used in fluid power systems can fail in various modes. The system designer is warned to consider the failure modes of all component parts used in fluid power systems and to provide adequate safeguards to prevent personal injury or damage to equipment in the event of such failure.

System designers must provide a warning to end users in the system instructional manual if protection against a failure mode cannot be adequately provided.

System designers and end users are cautioned to review specific warnings found in instruction sheets packed and shipped with these products.