

- > Port size: DN 8 ... 50, 1/4 ... 2 (ISO G/NPT)
- > High flow rate
- > For robust industry solutions
- > Damped operation
- > Suitable for vacuum
- > For systems with low or fluctuating pressure
- > Valve operates without differential pressure
- > Solenoid interchangeable without tools (*Click-on®*)

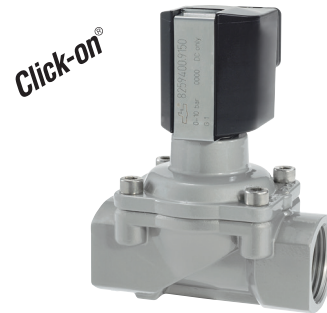

### Technical features

**Medium:**

Slightly aggressive gases and liquids

**Switching function:**

Normally closed

**Operation:**

Solenoid actuated, with forced lifting

**Mounting position:**

Optional, preferably solenoid vertical on top

**Flow direction:**

Determined

**Port size:**

G1/4, G3/8, G1/2, G3/4, G1, G1 1/4, G1 1/2, G2 1/4 NPT, 3/8 NPT, 1/2 NPT, 3/4 NPT, 1 NPT, 1 1/4 NPT, 1 1/2 NPT, 2 NPT

**Operating pressure:**

See table

**Fluid temperature:**

-10 ... +90°C (+14° ... +194°F)

**Ambient temperature:**

-10 ... +50°C (+14° ... +122°F)

**Material:**

Body: Stainless steel (1.4408)

Seat seal: NBR-K

Internal parts: Stainless steel, PVDF

For contaminated fluids insertion of a strainer is recommended.

### Technical data - standard models

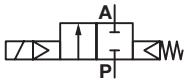
Symbol	Port size	Orifice (mm)	Flow kv value *1) (m³/h)	Operating pressure *2) (bar)	Weight (kg)	Model Solenoid V d.c.	Model Solenoid V a.c.
	G1/4	8	1,9	0 ... 10	0,7	8259000.9151.xxxxx	8259000.9154.xxxxx
	1/4 NPT	8	1,9	0 ... 10	0,7	8449000.9151.xxxxx	8449000.9154.xxxxx
	G3/8	10	3	0 ... 10	0,7	8259100.9151.xxxxx	8259100.9154.xxxxx
	3/8 NPT	10	3	0 ... 10	0,7	8449100.9151.xxxxx	8449100.9154.xxxxx
	G1/2	12	3,4	0 ... 10	0,8	8259200.9151.xxxxx	8259200.9154.xxxxx
	1/2 NPT	12	3,4	0 ... 10	0,8	8449200.9151.xxxxx	8449200.9154.xxxxx
	G3/4	20	5,8	0 ... 10	0,9	8259300.9151.xxxxx	8259300.9154.xxxxx
	3/4 NPT	20	5,8	0 ... 10	0,9	8449300.9151.xxxxx	8449300.9154.xxxxx
	G1	25	8	0 ... 10	1,3	8259400.9151.xxxxx	8259400.9154.xxxxx
	1 NPT	25	8	0 ... 10	1,3	8449400.9151.xxxxx	8449400.9154.xxxxx
	G1 1/4	32	23	0 ... 16	4,3	8259500.9401.xxxxx	8259500.9404.xxxxx
	1 1/4 NPT	32	23	0 ... 16	4,3	8449500.9401.xxxxx	8449500.9404.xxxxx
	G1 1/2	40	25	0 ... 16	4,1	8259600.9401.xxxxx	8259600.9404.xxxxx
	1 1/2 NPT	40	25	0 ... 16	4,1	8449600.9401.xxxxx	8449600.9404.xxxxx
	G2	50	41	0 ... 16	5,1	8259700.9401.xxxxx	8259700.9404.xxxxx
	2 NPT	50	41	0 ... 16	5,1	8449700.9401.xxxxx	8449700.9404.xxxxx

xxxxx Please insert voltage and frequency codes

\*1) Cv-value (US) ≈ kv value x 1,2

\*2) For gases and liquid fluids up to 25 mm²/s (cSt)

G1/4 ... G1 resp. 1/4 NPT ... 1 NPT max. 16 bar on request

**Option selector**

8★9★\*★\*★\*★\*★\*★\*★\*★\*★\*

Thread form	Substitute
ISO G	25
NPT	44
Port size	Substitute
1/4	0
3/8	1
1/2	2
3/4	3
1	4
1 1/4	5
1 1/2	6
2	7
Valve options	Substitute
Normally open (NO), up to G1 (1 NPT) with solenoid 9150 max. 10 bar (145 psi), with solenoid 8300 max. 16 bar (232 psi), with solenoid 9300 max. 16 bar (232 psi), from G1 1/4 (1 1/4 NPT) only with solenoid 8400 max. 16 bar (232 psi)	01
Manual override, from G1 1/4 (1 1/4 NPT)	02
Seat seal FPM, Fluid temperature -5 ... +110°C	03
Seat seal EPDM, for hot water, Fluid temperature -10 ... +110°C	14
Normally open, Seat seal FPM, Fluid temperature -5 ... +110°C, from G1 1/4 (1 1/4 NPT) only with solenoid 8400	17
Version for drinking water with test according to KTW	88

Frequency	Substitute
See table frequency codes	xx
Voltage	Substitute
See table voltage codes	xxx
Solenoid options	Substitute
G1/4 ... 1 Operating pressure 0 ... 10 bar Solenoid in V d.c.	9151
G1 1/4 ... 2 Operating pressure 0 ... 16 bar Solenoid in V d.c.	9401
G1/4 ... 1 Operating pressure 0 ... 10 bar Solenoid in V a.c.	9154
G1 1/4 ... 2 Operating pressure 0 ... 16 bar Solenoid in V a.c.	9404

### Standard solenoid systems

#### Voltage and Frequency Solenoid 9151/9154 \*1)

Code Voltage	Code Frequency	Voltage	Frequency	Power consumption	
				Inrush	Holding
024	00	24 V d.c.	-	18 W	18 W
024	49	24 V a.c.	40 ... 60 Hz	20 VA	20 VA
110	49	110 V a.c.	40 ... 60 Hz	20 VA	20 VA
120	49	120 V a.c.	40 ... 60 Hz	20 VA	20 VA
230	49	230 V a.c.	40 ... 60 Hz	20 VA	20 VA

#### Voltage and Frequency Solenoid 9301/9304 \*1)

Code Voltage	Code Frequency	Voltage	Frequency	Power consumption	
				Inrush	Holding
024	00	24 V d.c.	-	18 W	18 W
024	49	24 V a.c.	50 Hz	20 VA	20 Hz
110	49	110 V a.c.	50 Hz	20 VA	20 Hz
120	49	120 V a.c.	60 Hz	20 VA	20 Hz
230	49	230 V a.c.	50 Hz	20 VA	20 Hz

#### Voltage and Frequency Solenoid 9401/9404 \*1)

Code Voltage	Code Frequency	Voltage	Frequency	Power consumption	
				Inrush	Holding
024	00	24 V d.c.	-	38 W	38 W
024	49	24 V a.c.	40 ... 60 Hz	42 VA	42 VA
110	49	110 V a.c.	40 ... 60 Hz	42 VA	42 VA
120	49	120 V a.c.	40 ... 60 Hz	42 VA	42 VA
230	49	230 V a.c.	40 ... 60 Hz	42 VA	42 VA

#### Voltage and Frequency Solenoid 8401/8404

Code Voltage	Code Frequency	Voltage	Frequency	Power consumption	
				Inrush	Holding
024	00	24 V d.c.	-	40 W	40 W
024	49	24 V a.c. *2)	40 ... 60 Hz	45 VA	45 VA
110	49	110 V a.c. *2)	40 ... 60 Hz	45 VA	45 VA
120	49	120 V a.c. *2)	40 ... 60 Hz	45 VA	45 VA
230	49	230 V a.c. *2)	40 ... 60 Hz	45 VA	45 VA

\*1)  only (with the exception of solenoid 94xx up to 41 V a.c.)  
 \*2) A.c. only with rectifier plug

Further versions on request!

### Electrical details for all solenoid systems

<b>Design</b>	DIN VDE 0580
<b>Voltage range</b>	±10%
<b>Duty cycle</b>	100% ED
<b>Protection class</b>	EN 60529 IP65
<b>Socket</b>	Form A acc. to DIN EN 175301-803 (included)

According to DIN VDE 0580 at a solenoid temperature of +20°C.  
 At operating state temperature the input power of a coil decreases by up to ca. 30% due to physical reasons.



### Additional solenoid systems (available from April 2018)

ATEX category	ATEX protection class	IP protection class	So-lenoid	Standard voltages	Old variant
II 3G II 3D	Ex nA IIB T4 Gc Ex tc IIIB T130°C Dc	IP65	8426	24 V d.c.	/
II 3G II 3D	Ex nA IIB T4 Gc Ex tc IIIB T130°C Dc	IP65	9176	24 V d.c.	/
II 3G II 3D	Ex nA IIB T4 Gc Ex tc IIIB T130°C Dc	IP65	9426	24 V d.c.	/
II 2G II 2D	Ex eb mb IIC T3 Gb Ex mb tb IIIB T140°C Db	IP66	6120	24 V d.c., 110 V a.c., 230 V a.c.	9191
II 2G II 2D	Ex eb mb IIC T3 Gb Ex mb tb IIIB T140°C Db	IP66	6240	24 V d.c., 110 V a.c., 230 V a.c.	8441

#### Attention!

The conditions imposed on the Ex approvals lead to reduction of the permissible standard temperature ranges in the cases of explosion protected solenoids.

**Section View**

**G1/4 ... 1**  
**1/4 ... 1 NPT**

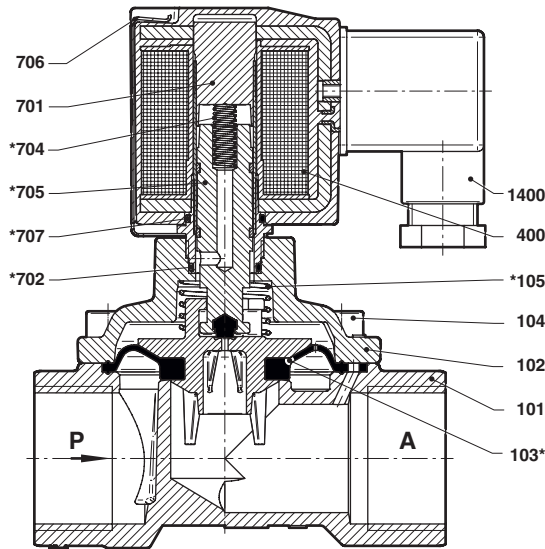

No.	Description
101	Valve body
102	Valve cover
*103	Diaphragm
104	Allen head screw
*105	Pressure spring
400	Solenoid
701	Core tube
*702	O-ring
*704	Pressure spring
*705	Core
706	Spring clip
*707	O-ring
1400	Socket (included)

**G1 1/4 ... 2**  
**1 1/4 ... 2 NPT**

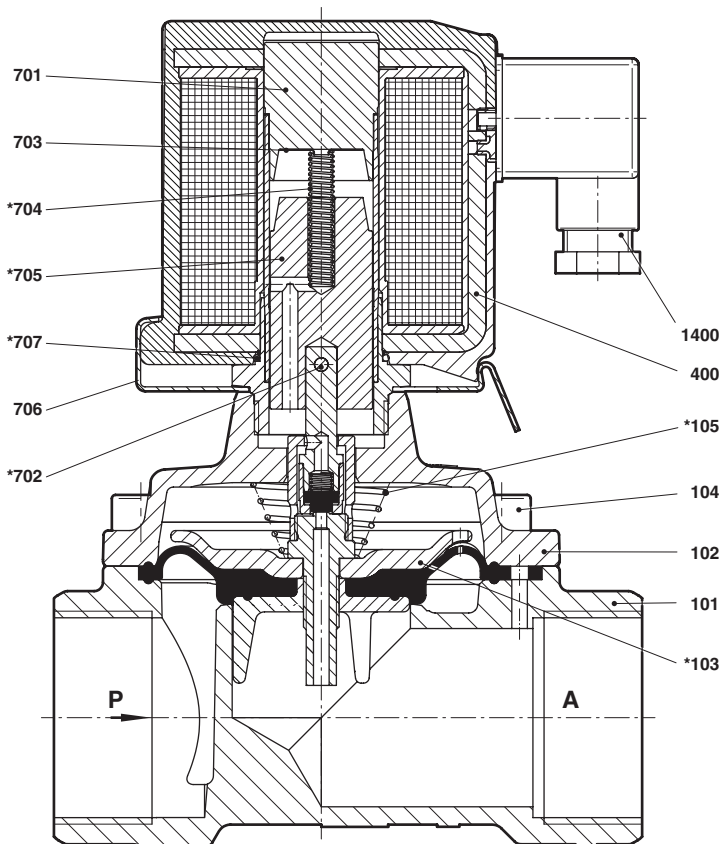

No.	Description
101	Valve body
102	Valve cover
*103	Diaphragm
104	Allen head screw
*105	Pressure spring
400	Solenoid
701	Core tube
*702	O-ring
*704	Pressure spring
*705	Core
706	Spring clip
*707	O-ring
1400	Socket (included)

\* These individual parts form a complete wearing unit.  
When ordering spare parts please state Model No. and Series No.

**Dimensions**

G1/4 ... 1  
1/4 ... 1 NPT

Dimensions in mm  
Projection/First angle

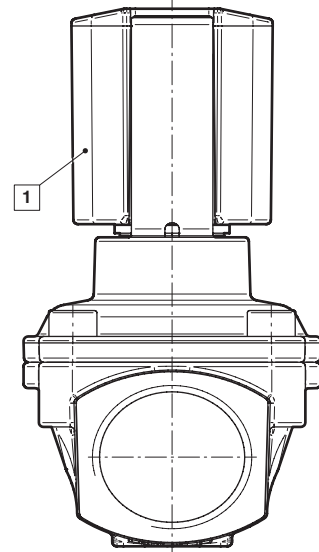
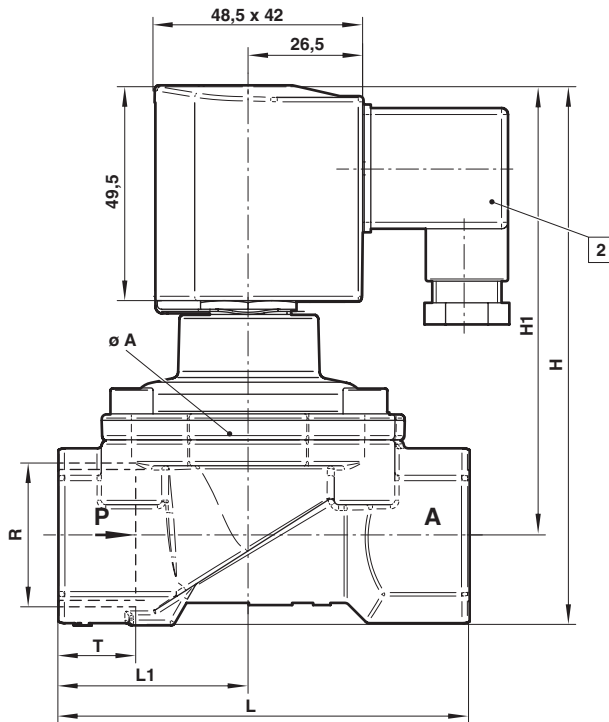

G1 1/4 ... 2  
1 1/4 ... 2 NPT

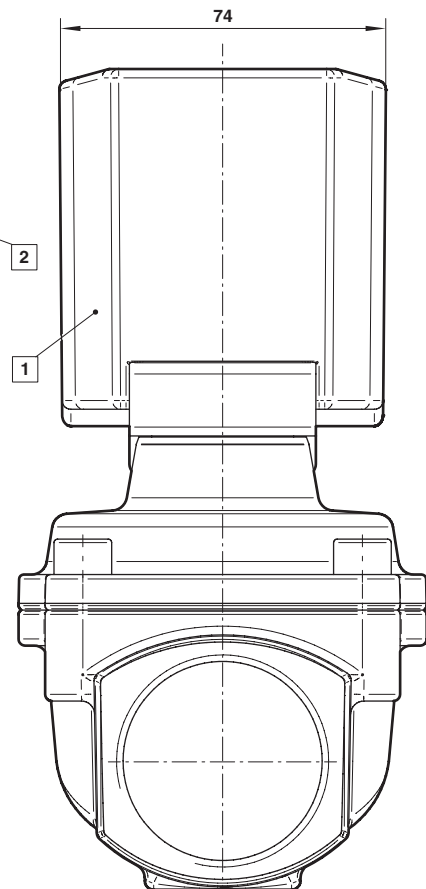
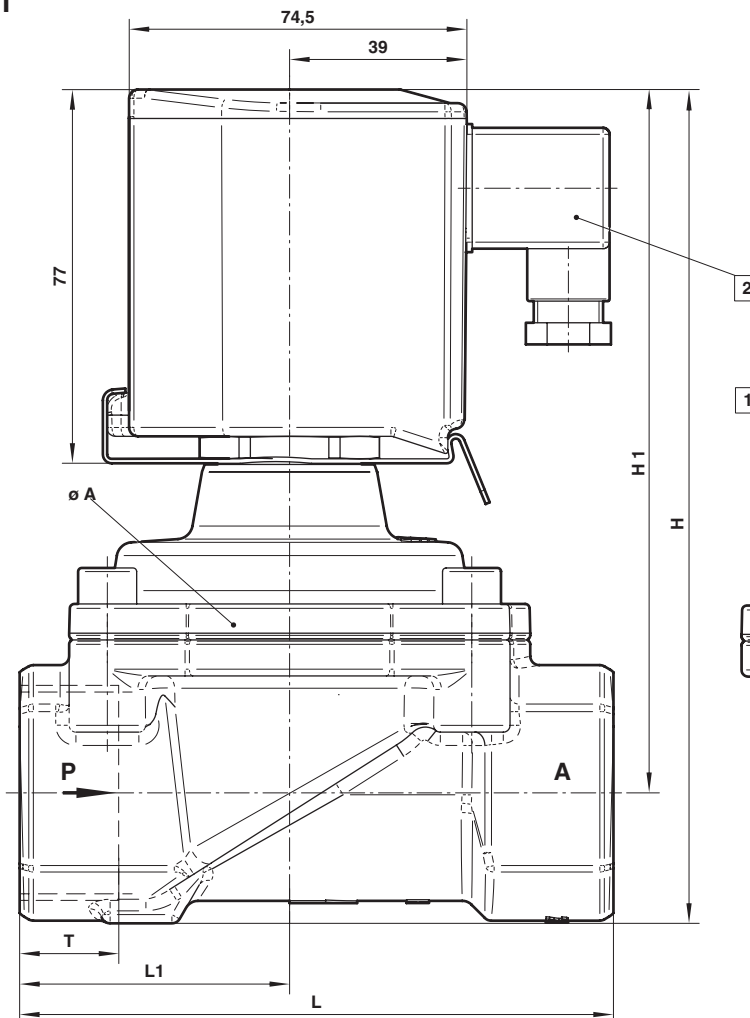

- 1 Solenoid rotatable 360°
- 2 Socket turnable 4 x 90°  
(Socket included)

## Dimensions

### G1/4 ... 2

### 1/4 ... 2 NPT

Port size R	ø A	H	H1	L	L1	T	Model
G1/4	44	104	92,5	60	27,5	12	8259000.915x.xxxxx
1/4 NPT	44	104	92,5	60	27,5	10	8449000.915x.xxxxx
G3/8	44	104	92,5	60	27,5	12	8259100.915x.xxxxx
3/8 NPT	44	104	92,5	60	27,5	10,5	8449100.915x.xxxxx
G1/2	44	108	94,5	67	31	14	8259200.915x.xxxxx
1/2 NPT	44	108	94,5	67	31	13,5	8449200.915x.xxxxx
G3/4	50	115	99	80	36,5	16	8259300.915x.xxxxx
3/4 NPT	50	115	99	80	36,5	14	8449300.915x.xxxxx
G1	62	124	103,5	95	44	18	8259400.915x.xxxxx
1 NPT	62	124	103,5	95	44	17	8449400.915x.xxxxx
G1 1/4	92	186	157	132	60	20	8259500.940x.xxxxx
1 1/4 NPT	92	186	157	132	60	17	8449500.940x.xxxxx
G1 1/2	92	186	157	132	60	22	8259600.940x.xxxxx
1 1/2 NPT	92	186	157	132	60	17	8449600.940x.xxxxx
G2	109	201,5	167	160	74	24	8259700.940x.xxxxx
2 NPT	109	201,5	167	160	74	17,5	8449700.940x.xxxxx

#### Note to Pressure Equipment Directive (PED):

The valves of this series, including the connection size DN 25 (G 1), are according to Art. 4 § 3 of the Pressure Equipment Directive (PED) 2014/68/EU. This means interpretation and production are in accordance to engineers practice wellknown in the member countries. The CE-sign at the valve refers not to the PED. Thus the declaration of conformity is not longer applicable for this directive.

#### For valves > DN 25 (G 1) Art. 3 § (1) No.1.4 applies:

The basic requirements of the Enclosure I of the PED must be fulfilled. The CE-sign at the valve includes the PED. A certificate of conformity of this directive will be available on request.

#### Note to Electromagnetic Compatibility Guideline (EEC):

The valves shall be provided with an electrical circuit which ensures the limits of the harmonised standards EN 61000-6-3 and EN 61000-6-1 are observed, and hence the requirements of the Electromagnetic Compatibility Guideline (2014/30/EU) satisfied.