

**3 Way Proportional Pressure Control Valve
with integrated electronic pressure control
Poppet valve
Nominal diameter (ND) 2, 4, 8, 12, 20**

- Free of lacquer affecting substances
- Combines valve and electronic control unit
- Good linearity
- Good response sensitivity
- Fast response time
- Adjustable amplification control
- Adjustable pressure range
- Threshold switch (comparator)
- Valve conforms to CE



Technical Data

Medium:

Filtered compressed air, lubricated or unlubricated

Filter 50 µm

Fluid temperature:

-5 to +50°C

Operation:

Proportional solenoid

Connection:

Flange type with subplate

G 1/8, G 1/4, G 3/8, G 1/2, G 3/4

Mounting position:

Any, preferable vertical (solenoid above)

Flow direction:

Defined (see scheme)

Operating temperature:

0 to +60°C

Material:

Valve housing: Aluminium alloy

Electronic housing: ABS

Seals: NBR (Perbunan)

Degree of protection: IP 65 (M12-variant)

Operating pressure $p_{1 \text{ max}}$:

7 bar, 12 bar, 16,5 bar

Setting pressure p_2 :

0 (0,03) – 2 bar, 0 (0,15) – 10 bar, 0 (0,24) – 16 bar

Hysteresis:

< 0.5 [% $p_2 \text{ max}$]

Repeatability:

< 0.5 [% $p_2 \text{ max}$]

Linearity:

< 1 [% $p_2 \text{ max}$]

Response sensitivity:

< 0.2 [% $p_2 \text{ max}$]

Ordering Information

3 way proportional pressure control valve,
Nominal diameter 2, operating pressure 0,15 to
10 bar, set point 0 to 10 V, connector 1 x M12
Type: 4095010.9000.024.00

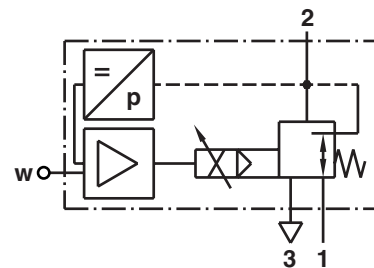

Versions with integrated electronic pressure control

For different set point inputs:

0 - 10 V, 0 - 20 mA, 4 - 20 mA, digital 8 bit with memory function

Actual value output:

0 - 10 V, 0 - 20 mA, 4 - 20 mA

Threshold switch (comparator):

Adjustment of tolerance and response time

Adjustable pressure range

Internal set point: Adjustable potentiometer

Electromagnetic Compatibility

The valves conform to the EC requirements EN50081-2 (emission) und EN50082-2 (disturbance noise). For this specification shielded cables have to be used.



General Information

2 x Connector (2 x M12 or 1 x M12 + 14 pole)

Type	Pressure setting p ₂ (bar)	Operating pressure max. p ₁ (bar)	Set point input w	Actual value output x	Pressure range adjustment	Comperator fixed	Comperator variable	Connection diagram No.	Connector Variant
4094x00.9000.024.00	0 ... 2	7	0 ... 10 V	0 ... 10 V	x	x		1	A + B
4094x01.9000.024.00			0 ... 20 mA	0 ... 10 V	x	x		1	A + B
4094x02.9000.024.00			4 ... 20 mA	0 ... 10 V	x	x		1	A + B
4094x03.9000.024.00			8 bit parallel	0 ... 10 V	x	x		3	A + D
4094x04.9000.024.00			0 ... 10 V	0 ... 10 V	x		x	1	A + B
4094x05.9000.024.00			0 ... 20 mA	0 ... 10 V	x		x	1	A + B
4094x06.9000.024.00			4 ... 20 mA	0 ... 10 V	x		x	1	A + B
4094x07.9000.024.00			0 ... 10 V	4 ... 20 mA	x		x	1	A + B
4094x09.9000.024.00			4 ... 20 mA	4 ... 20 mA	x		x	1	A + B
4094x10.9000.024.00	0 ... 10	12	0 ... 10 V	0 ... 10 V	x	x		1	A + B
4094x11.9000.024.00			0 ... 20 mA	0 ... 10 V	x	x		1	A + B
4094x12.9000.024.00			4 ... 20 mA	0 ... 10 V	x	x		1	A + B
4094x13.9000.024.00			8 bit parallel	0 ... 10 V	x	x		3	A + D
4094x14.9000.024.00			0 ... 10 V	0 ... 10 V	x		x	1	A + B
4094x15.9000.024.00			0 ... 20 mA	0 ... 10 V	x		x	1	A + B
4094x16.9000.024.00			4 ... 20 mA	0 ... 10 V	x		x	1	A + B
4094x17.9000.024.00			0 ... 10 V	4 ... 20 mA	x		x	1	A + B
4094x19.9000.024.00			4 ... 20 mA	4 ... 20 mA	x		x	1	A + B
4094x26.9000.024.00	0 ... 16	16,5	0 ... 10 V	0 ... 10 V	x	x		1	A + B
4094x27.9000.024.00			0 ... 20 mA	0 ... 10 V	x	x		1	A + B
4094x28.9000.024.00			4 ... 20 mA	0 ... 10 V	x	x		1	A + B
4094x29.9000.024.00			8 bit parallel	0 ... 10 V	x	x		3	A + D
4094x30.9000.024.00			0 ... 10 V	0 ... 10 V	x		x	1	A + B
4094x31.9000.024.00			0 ... 20 mA	0 ... 10 V	x		x	1	A + B
4094x32.9000.024.00			4 ... 20 mA	0 ... 10 V	x		x	1	A + B
4094x33.9000.024.00			0 ... 10 V	4 ... 20 mA	x		x	1	A + B
4094x35.9000.024.00			4 ... 20 mA	4 ... 20 mA	x		x	1	A + B

1 x Connector (1 x M12)

Type	Pressure setting p ₂ (bar)	Operating pressure max. p ₁ (bar)	Set point input w	Actual value output x	Pressure range adjustment	Comperator fixed	Comperator variable	Connection diagram No.	Connector Variant
4095x00.9000.024.00	0 ... 2	7	0 ... 10 V	0 ... 10 V	x			2	C
4095x01.9000.024.00			0 ... 20 mA	0 ... 10 V	x			2	C
4095x02.9000.024.00			4 ... 20 mA	0 ... 10 V	x			2	C
4095x07.9000.024.00			0 ... 10 V	4 ... 20 mA	x			2	C
4095x09.9000.024.00			4 ... 20 mA	4 ... 20 mA	x			2	C
4095x10.9000.024.00	0 ... 10	12	0 ... 10 V	0 ... 10 V	x			2	C
4095x11.9000.024.00			0 ... 20 mA	0 ... 10 V	x			2	C
4095x12.9000.024.00			4 ... 20 mA	0 ... 10 V	x			2	C
4095x17.9000.024.00			0 ... 10 V	4 ... 20 mA	x			2	C
4095x19.9000.024.00			4 ... 20 mA	4 ... 20 mA	x			2	C
4095x26.9000.024.00	0 ... 16	16,5	0 ... 10 V	0 ... 10 V	x			2	C
4095x27.9000.024.00			0 ... 20 mA	0 ... 10 V	x			2	C
4095x28.9000.024.00			4 ... 20 mA	0 ... 10 V	x			2	C
4095x33.9000.024.00			0 ... 10 V	4 ... 20 mA	x			2	C
4095x35.9000.024.00			4 ... 20 mA	4 ... 20 mA	x			2	C

The „x“ should be replaced by:

0 for ND 2

1 for ND 4

3 for ND 8

4 for ND 12/20

Subplates and plug connectors should be ordered separately (see accessories)



General Information

6 pole + PE Connector

Type	Pressure setting p ₂ (bar)	Operating pressure max. p ₁ (bar)	Set point input w	Actual value output x	Pressure range adjustment *)	Comperator fixed	Comperator variable	Connection diagram No.	Connector Variant
4091x00.9000.024.00	0 ... 2	7	0 ... 10 V	0 ... 10 V	x			4	E
4091x01.9000.024.00			0 ... 20 mA	0 ... 10 V	x			4	E
4091x02.9000.024.00			4 ... 20 mA	0 ... 10 V	x			4	E
4091x03.9000.024.00			8 bit parallel	0 ... 10 V	x			6	F
4091x10.9000.024.00	0 ... 10	12	0 ... 10 V	0 ... 10 V	x			4	E
4091x11.9000.024.00			0 ... 20 mA	0 ... 10 V	x			4	E
4091x12.9000.024.00			4 ... 20 mA	0 ... 10 V	x			4	E
4091x13.9000.024.00			8 bit parallel	0 ... 10 V	x			6	F
4091x16.9000.024.00			0 ... 10 V	0 ... 10 V	x		x	5	E
4091x26.9000.024.00	0 ... 16	16,5	0 ... 10 V	0 ... 10 V	x			4	E
4091x27.9000.024.00			0 ... 20 mA	0 ... 10 V	x			4	E
4091x28.9000.024.00			4 ... 20 mA	0 ... 10 V	x			4	E
4091x29.9000.024.00			8 bit parallel	0 ... 10 V	x			6	F

The „x“ should be replaced by:

0 for ND 2

1 for ND 4

3 for ND 8

4 for ND 12/20

*) Please, clarify the availability of the pressure range adjustment with the manufacturing site.

Subplates and plug connectors should be ordered separately (see accessories)

Accessories

Subplate			Silencer for venting port at subplate			Plug connector M12			Plug connector 6-/14-/15 pole		
Specification	Type	Type	Specification	Type	Type	Specification	Variant	Type	Specification	Variant	Type
ND 2 G 1/8	0542845	0014510	ND 2 G 1/8	0014510	A	M 12 x 1; 3 pole; 5 m 3 x 0,34 mm ²	A	0250079	14 pole; Pg 9	D	0799847
ND 4 G 1/8	0542848	0014610	ND 4 G 1/4	0014610	B	M 12 x 1; 4 pole; 5 m 4 x 0,34 mm ²	B	0250080	14 pole; 2 m 14 x 0,25 mm ²	D	0799857
ND 8 G 1/4	0542636	0014710	ND 8 G 3/8	0014710	C	M 12 x 1; 5 pole; 5 m 5 x 0,34 mm ²	C	0250081	14 pole; 5 m 14 x 0,25 mm ²	D	0250082
ND 8 G 3/8	0543705	0014810	ND 12 G 1/2	0014810	A	M 12 x 1; 3 pole; 10 m 3 x 0,34 mm ²	A	0250470	6 pole + PE 90° plastic	E	0660689
ND 12 G 1/2	0542814	0014910	ND 20 G 3/4	0014910	B	M 12 x 1; 4 pole; 10 m 4 x 0,34 mm ²	B	0250471	6 pole + PE metal, Pg 13,5	E	0799695
ND 20 G 3/4	0542840				C	M 12 x 1; 5 pole; 10 m 5 x 0,34 mm ²	C	0250472	15 pole MIL-C-26482	F	0680683



Electrical information

Supply

Supply voltage	U _B (VDC)	18 to 32
Residual ripple max	(%)	10
Power consumption at 24 V DC		
16 bar Valve size 2	I _B (A)	1,8
16 bar Valve size 4, 8, 12	I _B (A)	1,5
10 bar Valve size 2	I _B (A)	1,2
10 bar Valve size 4, 8, 12	I _B (A)	1,0
2 bar Valve size 2, 4, 8, 12	I _B (A)	0,8
Stand-by-operation	I _B (A)	< 0,05

Inputs (signal)

Analogue setpoints¹⁾ (w)

Voltage signal	U _E (V)	0 to 10
Input resistance	R _E (kΩ)	< 500
Current signal	I _E (mA)	0 to 20 / 4 to 20
Load resistance	(Ω)	≤ 135

Digital setpoints¹⁾ (w)

Data inputs (parallel)	(bit)	8 bit + enable
Level for logic „L“ ²⁾	(V)	0 to 2
Level for logic „H“	(V)	12 to 32
Enable *		Low active
Input current	(mA)	1

* see General information

Set point (W) intern (optional)¹⁾

Setting range	(V)	0 to 10
Pneumatic output pressure	(%)	0 to 100
Factory setting	(%)	0
Adjusting facility		Internal potentiometer

Electromagnetic compatibility

Noise immunity	To DIN EN 50082, Part 2
Noise transmission	To DIN EN 50081, Part 1

16 bar model ND 2 and ND 4

Should these valves be run at 100 % ED on a high pressure level / in a high pressure range for a longer time, the solenoid current will be reduced. Thereby the pressure setting p₂ will be decreased. This ensures the operational safety of the valves. This reaction of the system depends directly on the surrounding temperature. At an ED ≤ 50 %, the maximum pressure can be maintained over the whole range of temperature. This safety function does not work for the valves ND 4 until from +45 °C surrounding temperature.

Outputs (signal)

Actual value (X)

Voltage signal for Pneumatic Output pressure	U _A (V)	0 ... 2 bar 1 V = 0,2 bar 0 ... 10 bar 1 V = 1,0 bar 0 ... 16 bar 1 V = 1,6 bar
Output current	I _A (mA)	1
Current signal for Pneumatic Output pressure	I _A (0-20 mA)	0 ... 2 bar 1 mA = 0,1 bar 0 ... 10 bar 1 mA = 0,5 bar 0 ... 16 bar 1 mA = 0,8 bar
Current signal for Pneumatic Output pressure	I _A (4-20 mA)	0 ... 2 bar 1,6 mA = 0,2 bar 0 ... 10 bar 1,6 mA = 1,0 bar 0 ... 16 bar 1,6 mA = 1,6 bar

Comperator (fixed)

Signal output „pressure reached“ (x = w)

Switching range	(%p ₂ max)	± 2
Voltage signal for Pressure outside Switching range x ≠ w	(V)	0
Pressure reached (x = w)	(V)	U _B - 1,5
Output current max.	(mA)	10

Comperator (variable)

Signal output „pressure reached“ (x = w)

Switching range	(%p ₂ max)	0 to ± 20
Adjusting facility		Internal potentiometer
Factory setting	(%p ₂ max)	Middle position
Delay time (during pressure build-up)	(ms)	100 to 1200
Factory setting	(ms)	1200
Voltage signal for Pressure outside Switching range x ≠ w	(V)	0
Pressure reached (x = w)	(V)	U _B - 1,5
Output current max.	(mA)	10

¹⁾ Valve function is activated as soon as the set point is ≥ 1.5%. If the set point is < 1.5% the set pressure = 0 and the valve is in stand-by-mode.

²⁾ Input open = Logic L



Characteristic Curves

Static Characteristic curves ND 2 to ND 20

Flow characteristic curves ND 2

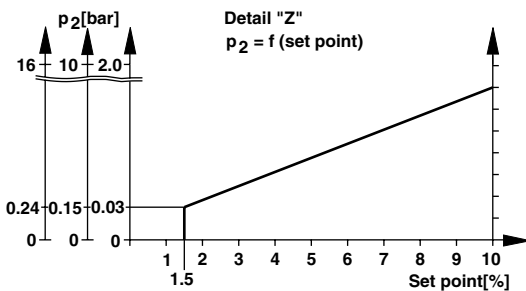
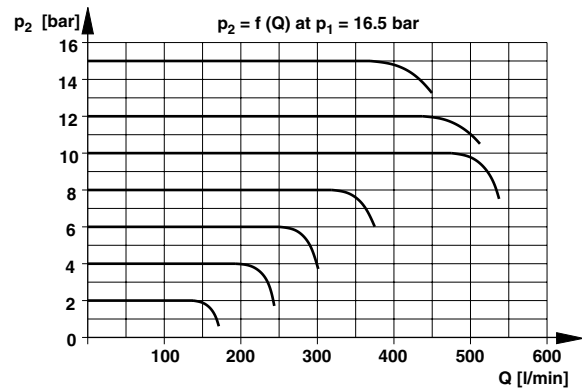
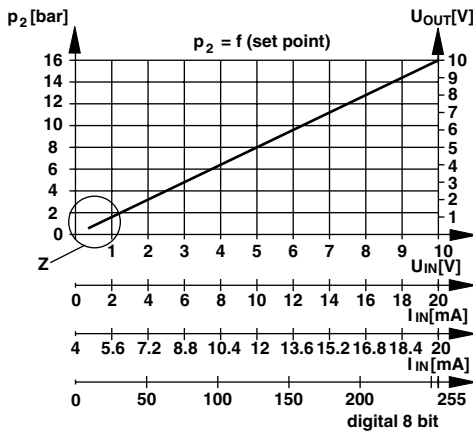
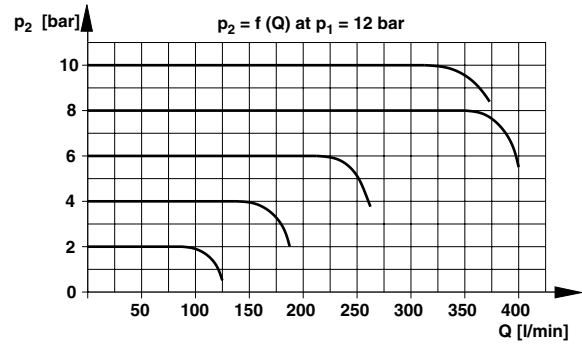
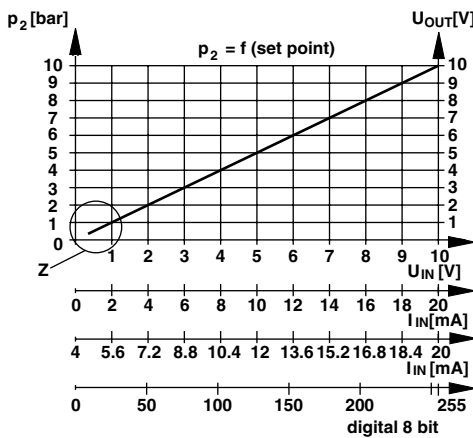
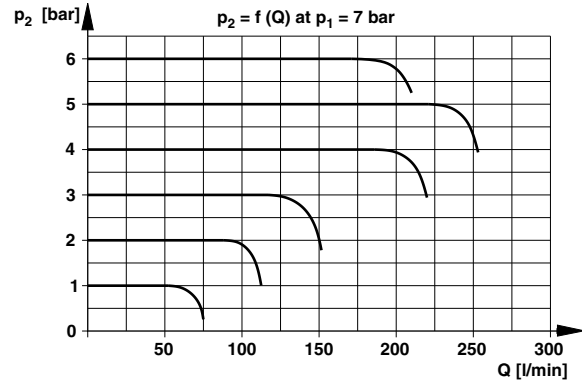
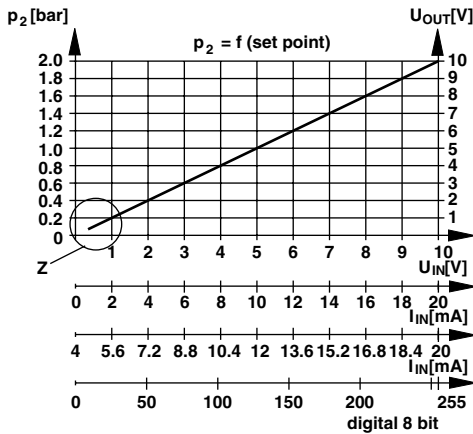

The valve function is activated as soon as the setpoint is $\geq 1,5\%$



Characteristic Curves

Flow characteristic curves ND 4

Flow characteristic curves ND 8

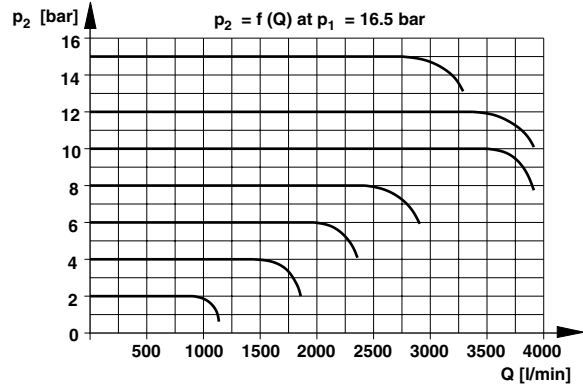
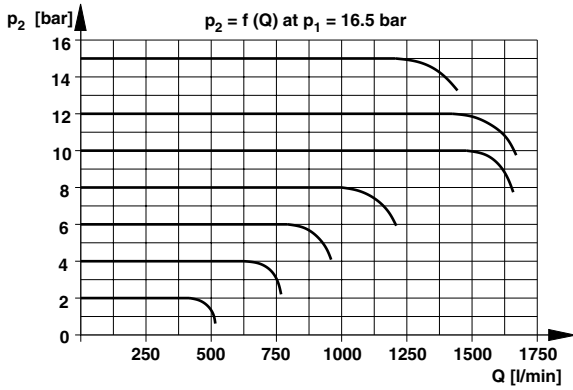
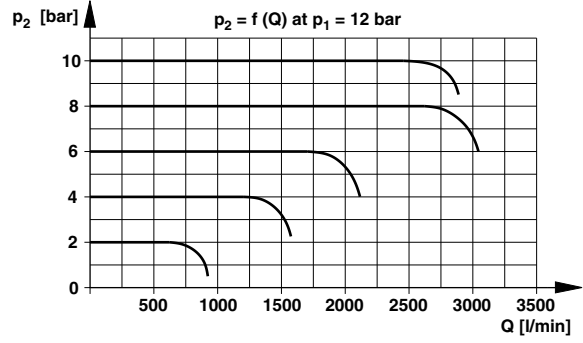
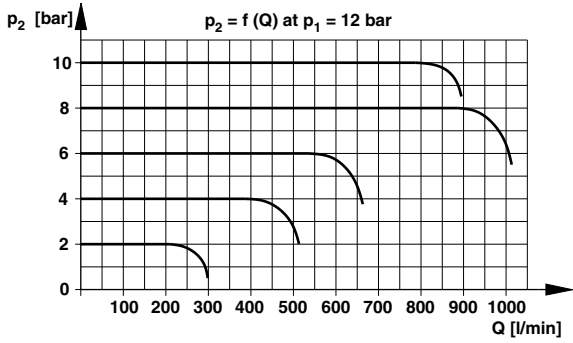
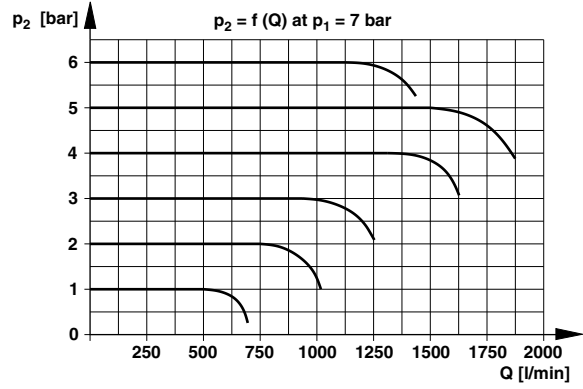
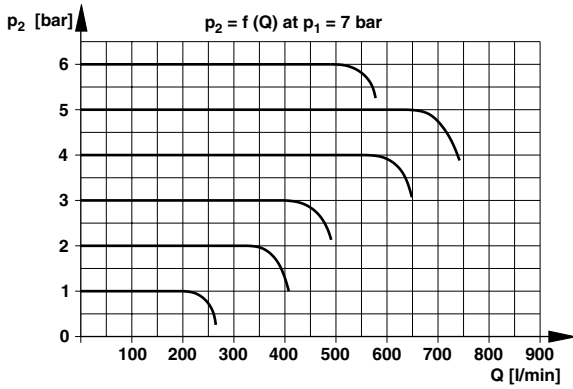



Characteristic Curves

Flow characteristic curves ND 12

Flow characteristic curves ND 20

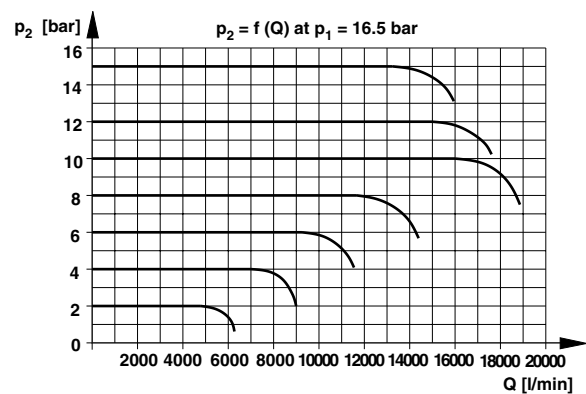
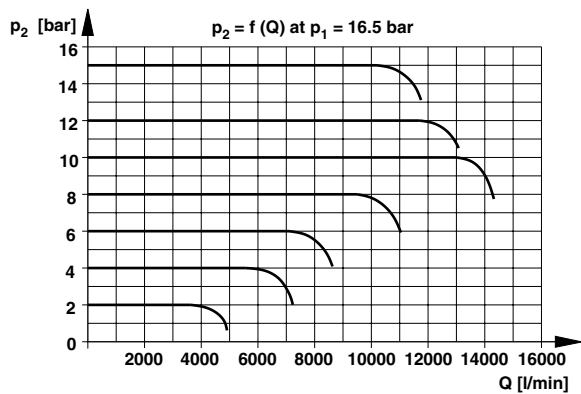
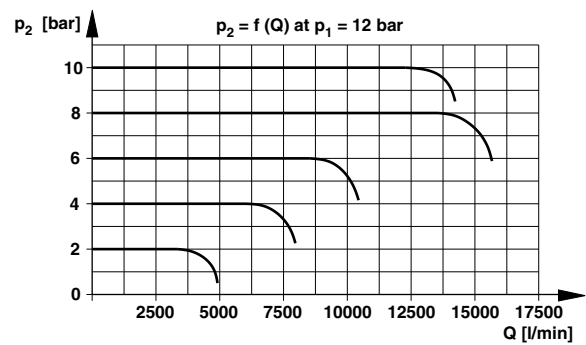
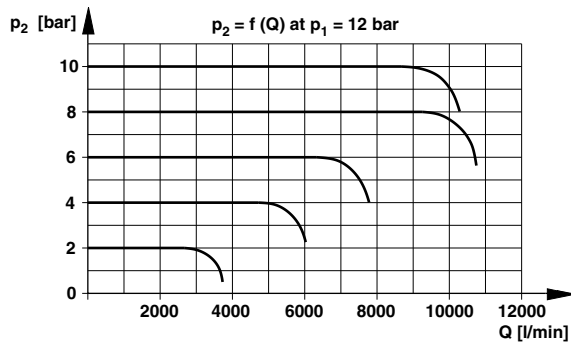
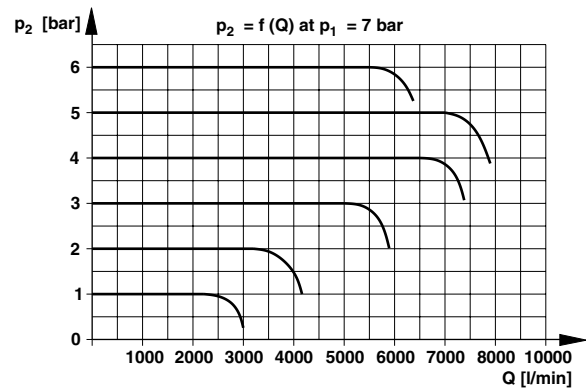
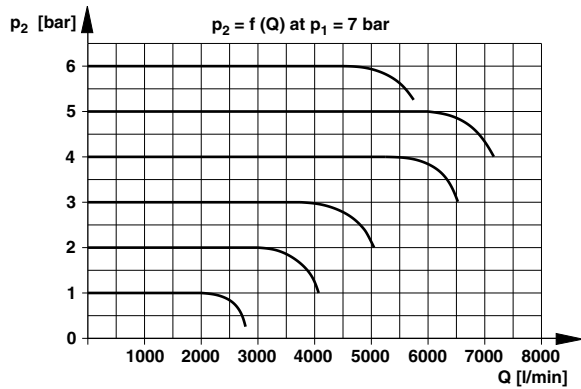



Functions/adjustment facilities (basic)

Block diagram (Basic)

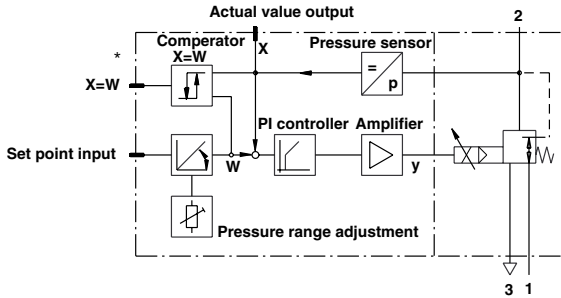

* Comperator according to 2 X connector

Switch over set point input

The set point input is factory pre-adjusted according to type no. In case of later change-over the accuracy will be reduced to $\pm 1.5\%$.

Setting the controller gain

The gain of the integrated controller is set in the factory to a value which allows universal use of the valve. If necessary, the controller gain can be varied to suit a specific pneumatic application of the valve. The controller gain can be changed by turning the potentiometer (under the screw plug in the electronics cover).
Factory setting in an application which requires permanent flow of air at the valve output 2 resp. for volume according to the table below:

ND	For volume approx. (cm ³)
2	0 ... 100
4	50 ... 500
8	100 ... 1500
12/20	1000 ... 8000

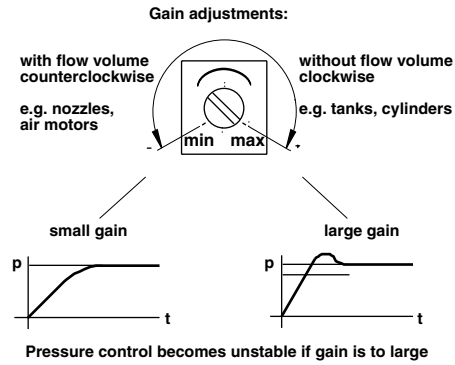
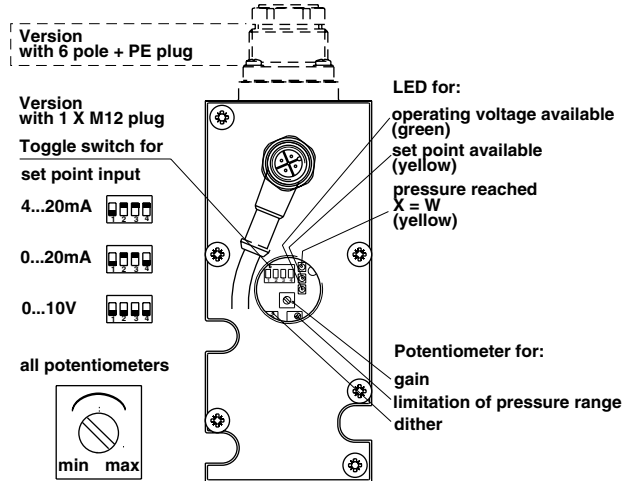

Comperator/Signal output (fixed) „pressure reached“ (x = w)

Description:
The function „Pressure reached“ enables the monitoring of the pressure control function.
The actual value is compared with the desired value (x = w). Identical values (selected pressure lying within the switching range) will cause a status signal at the output (x = w).
Switching range $\pm 2\%$ of p_2 max.

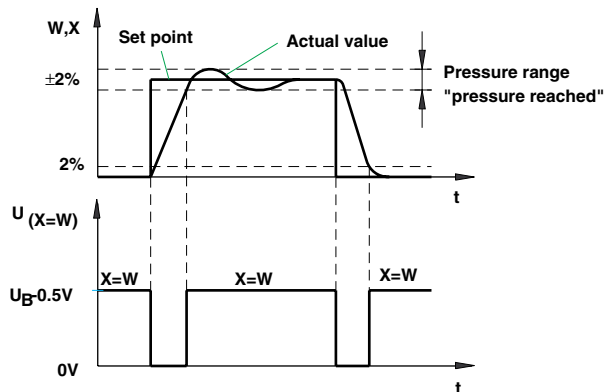



Pressure range adjustment

Description:

When delivered the relation between the set point pressure and the output pressure is adjusted to the prevailing pressure range (2 bar, 10 bar, 16 bar):

Set point corresponding to output pressure 100% 100%

The potentiometer „pressure range adjustment“ offers the possibility to change the pressure range. Meanwhile it is possible to decrease the set point pressure down to 10 % (see characteristic curve 10 %).

The valve always starts to respond at $p_2 \text{ min}$.

This means at a pressure range up to 2 bar = 0,03 bar
 10 bar = 0,15 bar
 16 bar = 0,24 bar.

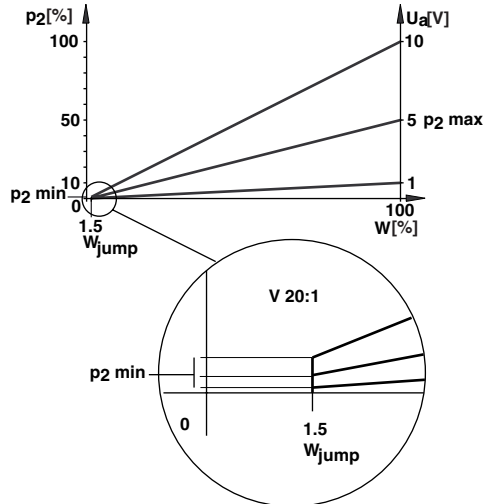

Functions/adjustment facilities (enlarged)

Block diagram (enlarged)

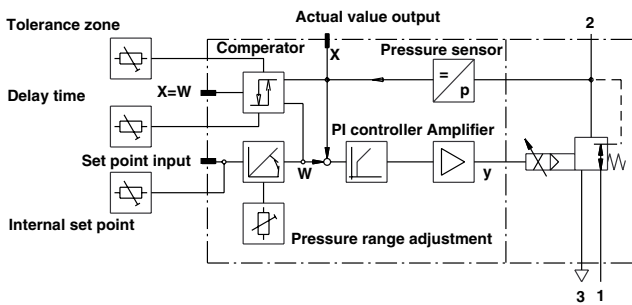

Internal set point

Should there be no set point, it is possible to adjust an internal set point via potentiometer (this must be activated by the factory). Then, however, an external adjustment of a set point is impossible.

Version with 2 X M12 plug

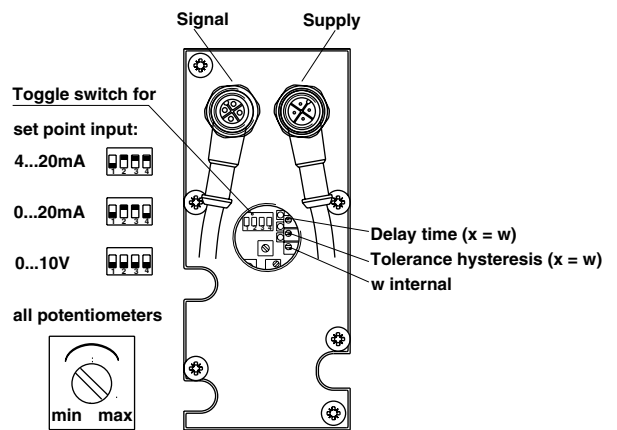

Comparator/Signal output (variable adjustable) „pressure reached“ (x = w)

Description:

The function „pressure reached“ enables the monitoring of the pressure control function.

The actual value is compared with the desired value ($x = w$). Identical values (selected pressure lying within the switching range) will cause a status signal at the output ($x = w$). Switching range $\pm 2\%$ of $p_2 \text{ max}$ (adjustable with potentiometer).

It is also possible to adjust the turn-on delay from 100 ms up to 1200 ms (adjustable with the potentiometer).

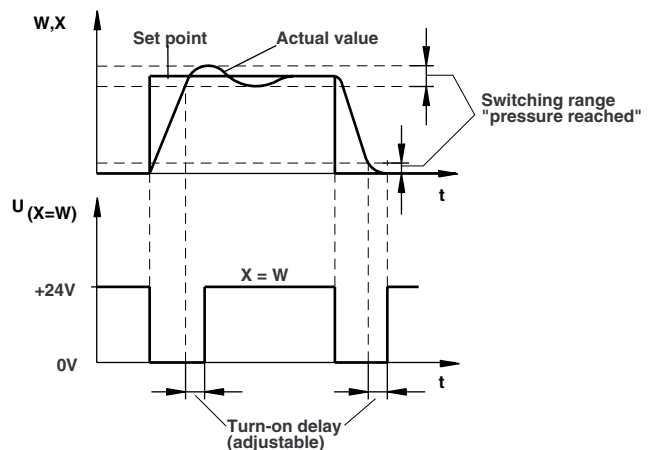



Electrical Connection Diagrams

Connection diagram 1

Valves with analogue set point input
2 connectors

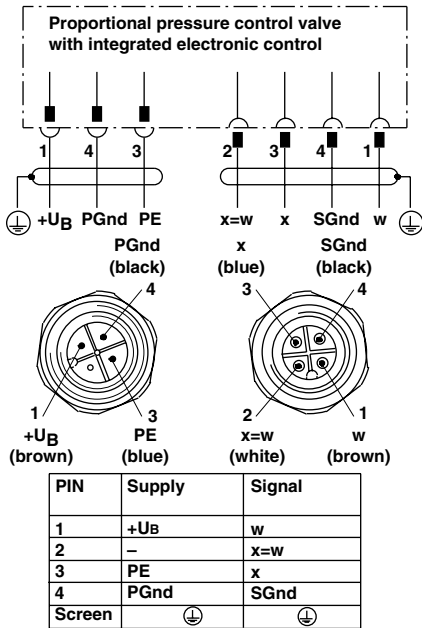

Connection diagram 2

Valves with analogue set point input
1 connector

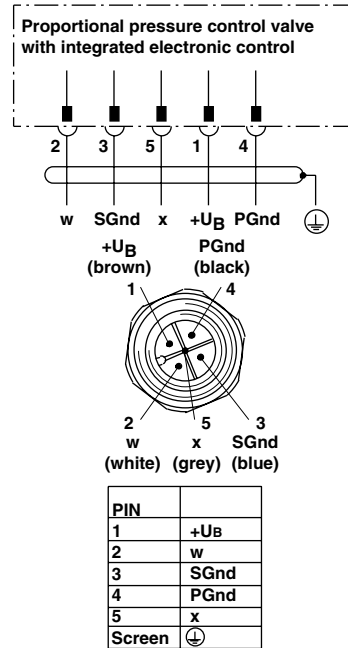

Explanation of the connections

+U _B	Supply voltage	w	Set point input
PGnd	Zero potential supply	x	Actual value output
SGnd	Zero potential signal	x = w	Comperator output
		PE	Protective ground

Connection diagram 3

Valves with digital set point input
2 connectors

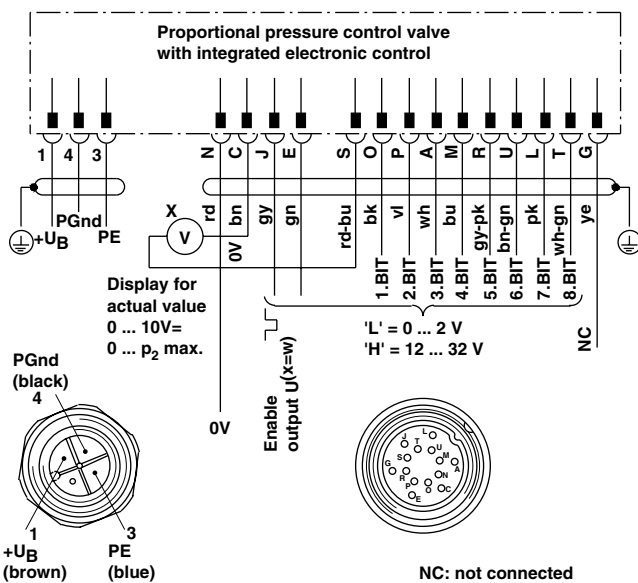

Notes on memory 1)

Logic table

T	L	U	R	M	A	P	O	J	Output signal
								L	As triggered at pins 0 to T
X	X	X	X	X	X	X	X	H	The previously-set value is stored; the triggered signals at pins 0 to T are ignored

¹⁾ If the memory function is not required, pin J can be ignored. In case of an interrupt of the valve function U_B the memory information is lost.

Conversion table for digital input signal

Signal at pin									Value z (decimal)	Valve version for pressure range p ₂ (bar)	
T	L	U	R	M	A	P	O	J		0 ... 2	0 ... 10
L	L	L	L	L	L	L	L	L	0	0,000	0,000
L	L	L	L	L	L	L	L	H	1	0,008	0,039
L	L	L	L	L	L	L	H	L	2	0,016	0,078
L	L	L	L	L	L	H	L	L	4	0,031	0,156
L	L	L	L	H	L	L	L	L	8	0,063	0,314
L	L	L	H	L	L	L	L	L	16	0,126	0,627
L	L	H	L	L	L	L	L	L	32	0,251	1,255
L	H	L	L	L	L	L	L	L	64	0,502	2,510
H	L	L	L	L	L	L	L	L	128	1,004	5,020
H	H	H	H	H	H	H	H	H	255	2,000	10,00

$$p_2 \text{ (bar)} = \frac{2}{255} \cdot x \cdot z \quad \frac{10}{255} \cdot x \cdot z$$

z = Sum of values triggered by „H“



Electrical Connection Diagrams

Connection diagram 4

Valves with analogue set point input

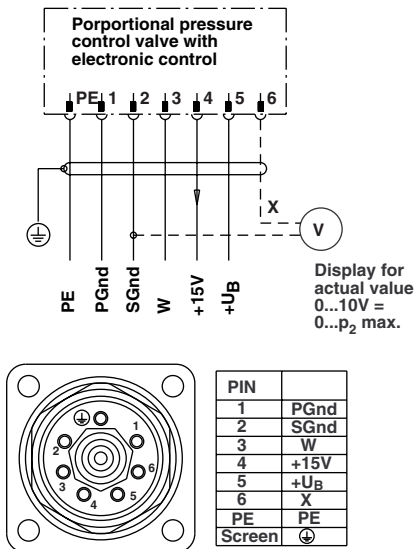

Connection diagram 5

Valves with analogue set point input

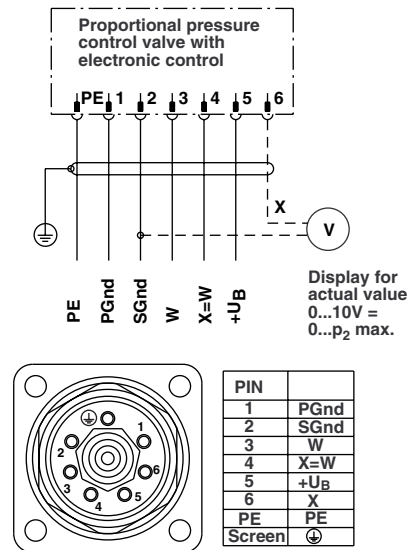

Explanation of the connections

+UB	Supply voltage	w	Set point input
PGnd	Zero potential supply	x	Actual value output
SGnd	Zero potential signal	x = w	Comperatur output
		PE	Protective earth

Connection diagram 6

Valves with digital set point input

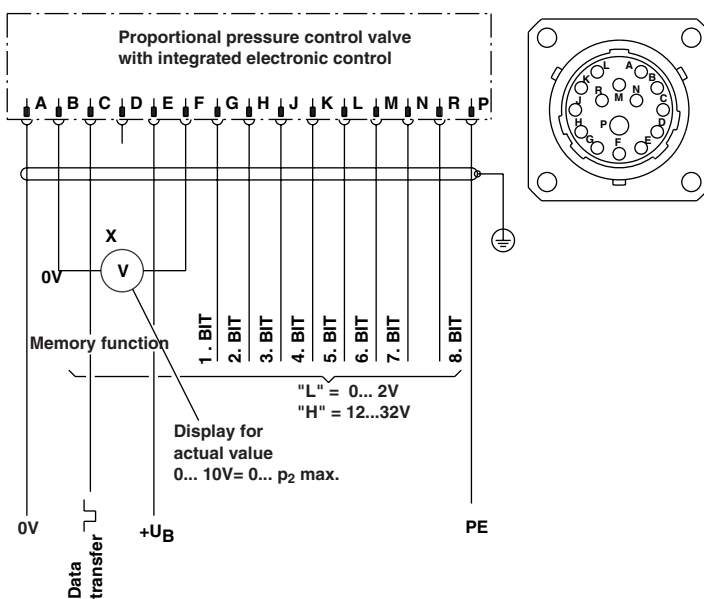

Notes on memory ¹⁾

Logic table

R	N	M	L	K	J	H	G	C	Output signal
								L	As triggered at pins G to R
X	X	X	X	X	X	X	X	H	The previously-set value is stored; the triggered signals at pins G to R are ignored

¹⁾ If the memory function is not required, pin C can be ignored. In case of an interrupt of the valve function U_B the memory information is lost.

Conversion table for digital input signal

Signal at pin									Value z (decimal)	Valve version for pressure range p ₂ (bar)		
R	N	M	L	K	J	H	G			0 ... 2	0 ... 10	0 ... 16
L	L	L	L	L	L	L	L	L	0	0,000	0,000	0,000
L	L	L	L	L	L	L	L	H	1	0,008	0,039	0,063
L	L	L	L	L	L	L	H	L	2	0,016	0,078	0,125
L	L	L	L	L	L	H	L	L	4	0,031	0,156	0,251
L	L	L	L	H	L	L	L	L	8	0,063	0,314	0,502
L	L	L	H	L	L	L	L	L	16	0,126	0,627	1,004
L	L	H	L	L	L	L	L	L	32	0,251	1,255	2,008
L	H	L	L	L	L	L	L	L	64	0,502	2,510	4,016
H	L	L	L	L	L	L	L	L	128	1,004	5,020	8,031
H	H	H	H	H	H	H	H	H	255	2,000	10,00	16,000

$$p_2 \text{ (bar)} = \frac{2}{255} \times z \quad \frac{10}{255} \times z \quad \frac{16}{255} \times z$$

z = Sum of values triggered by „H“



Basic dimensions Valves

Version with M12 plug

ND 2

Option without subplate

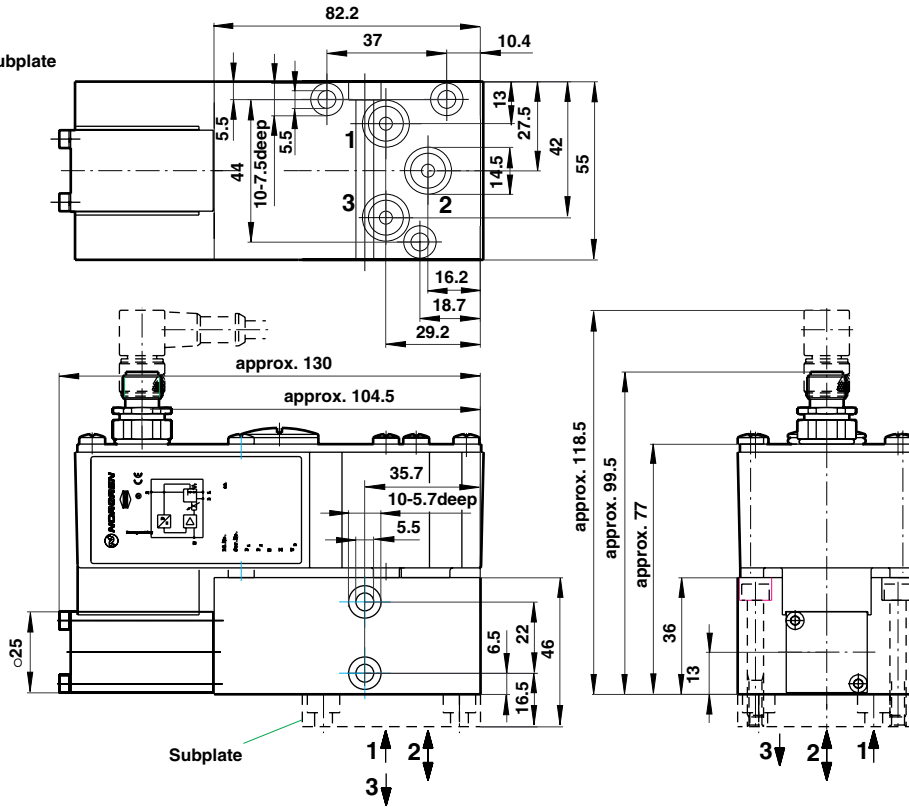

ND 4

Option without subplate

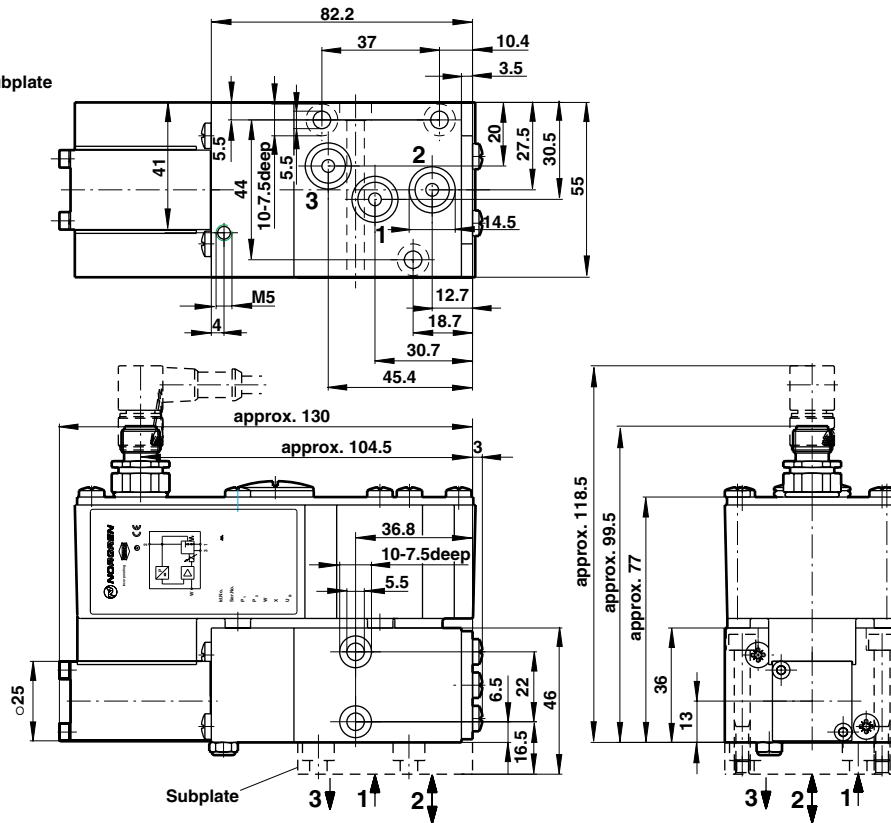



Basic dimensions Valves

Version with M12 plug

ND 8

Option without subplate

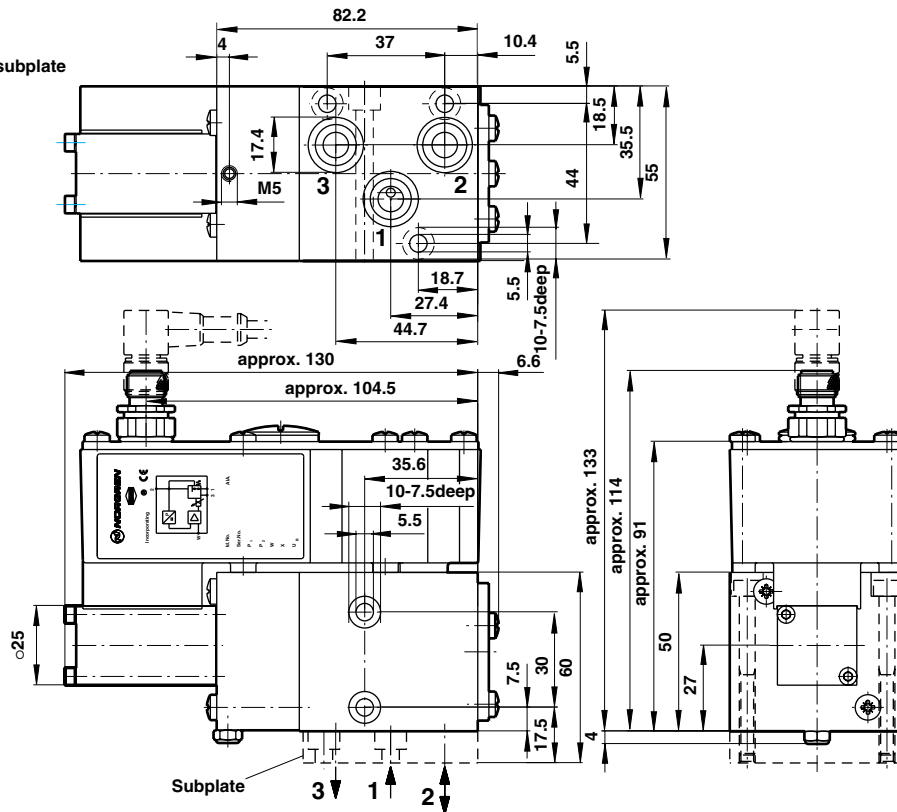

ND 12 / 20

Option without subplate

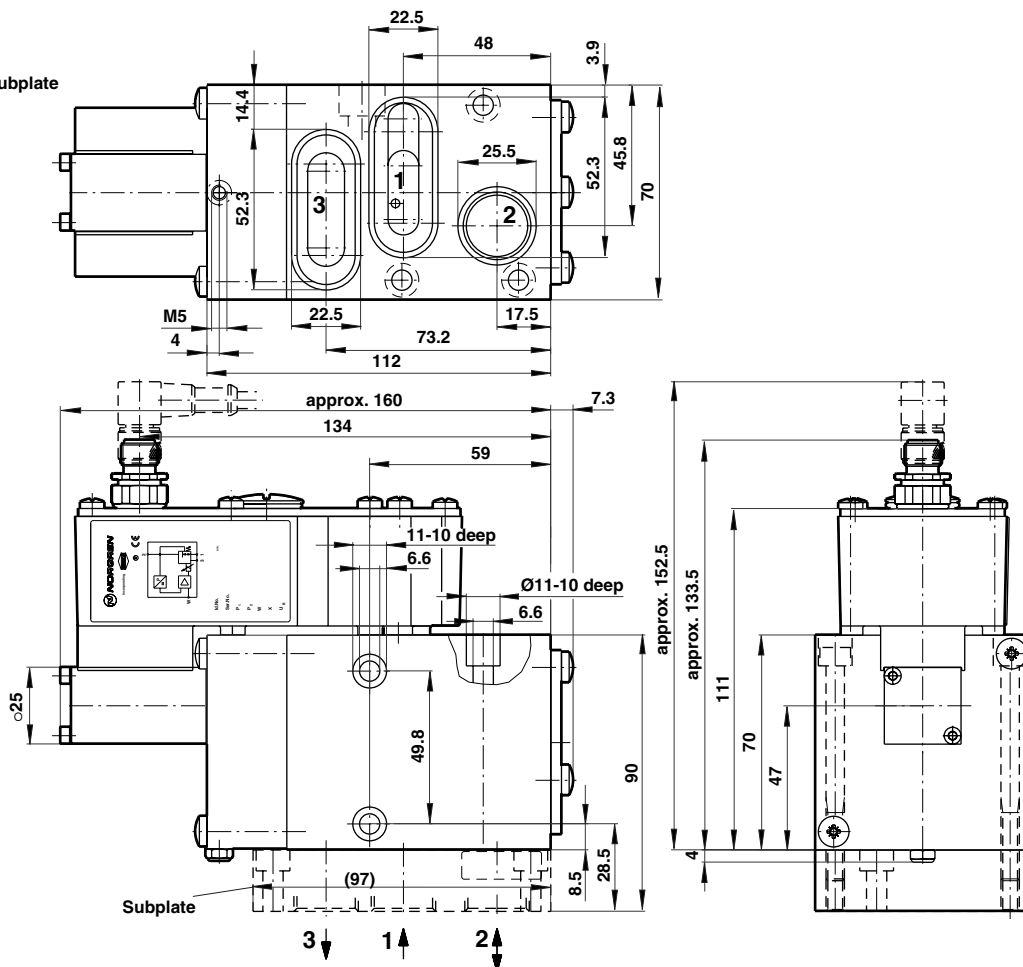



Basic dimensions Valves

Version with 6 pole + PE plug

ND 2

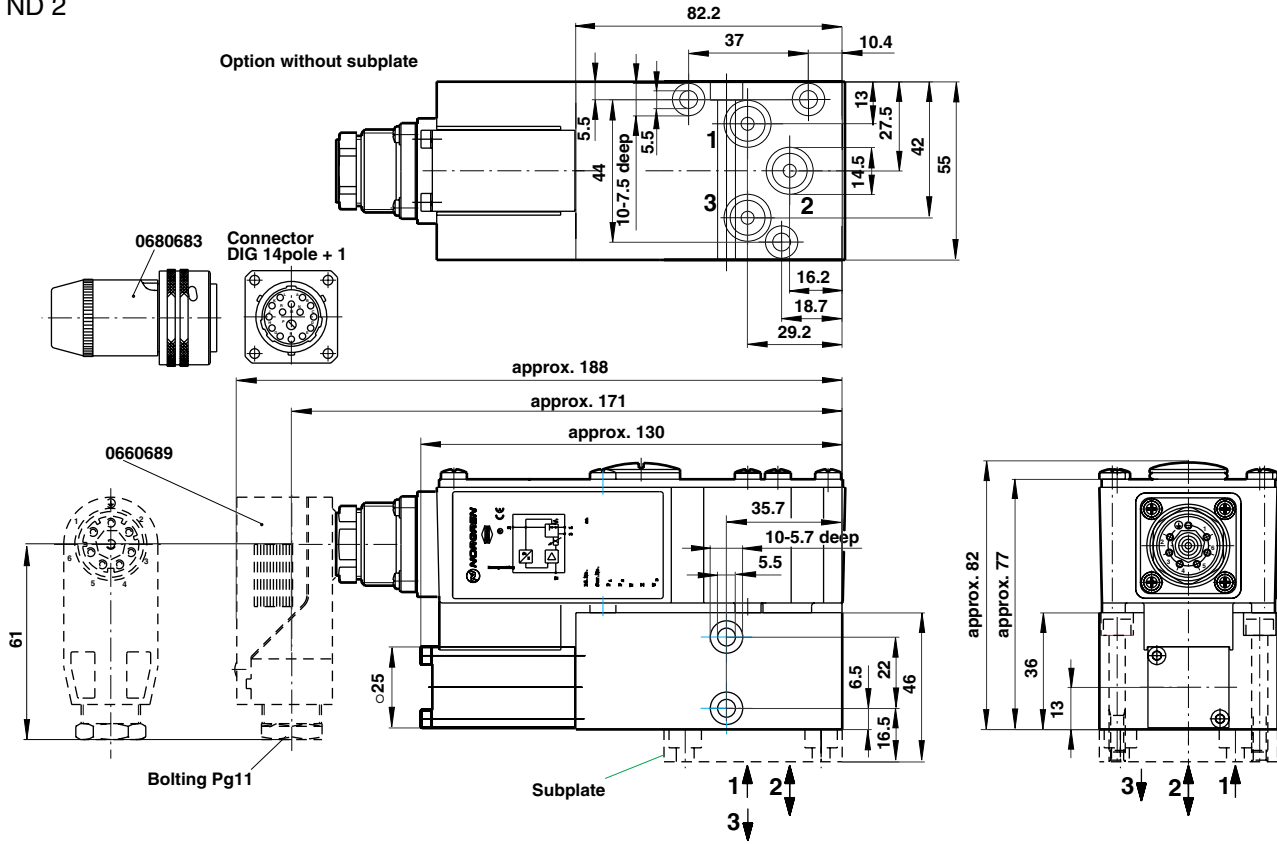

ND 4

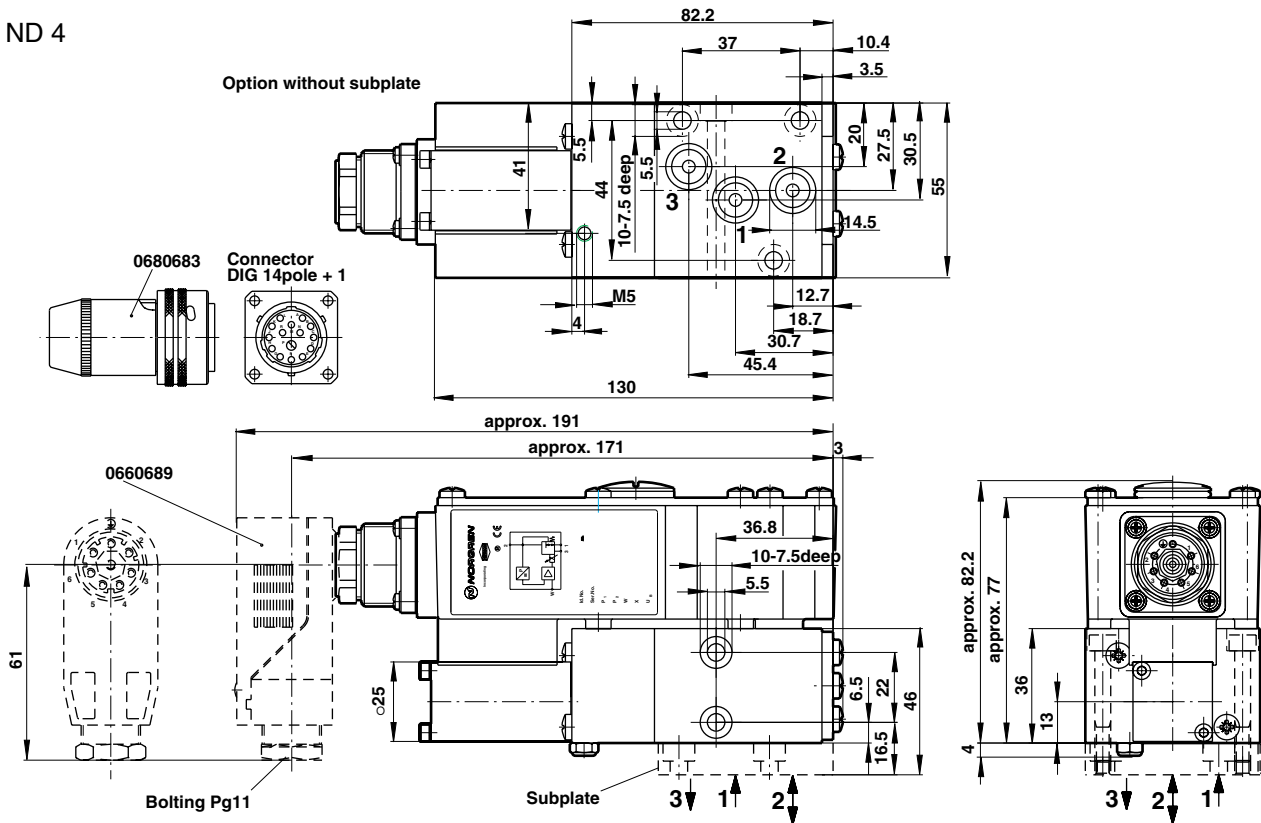



Basic dimensions Valves

Version with 6 pole + PE plug

ND 8

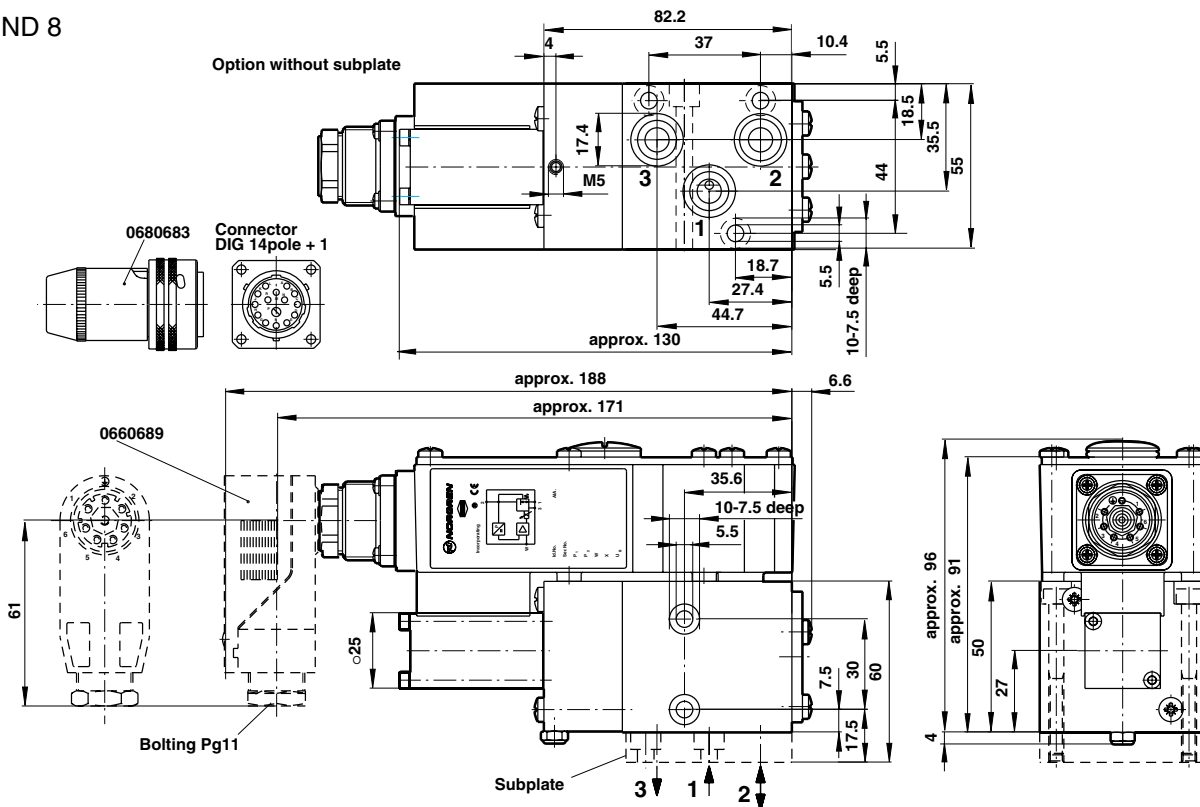

ND 12 / 20

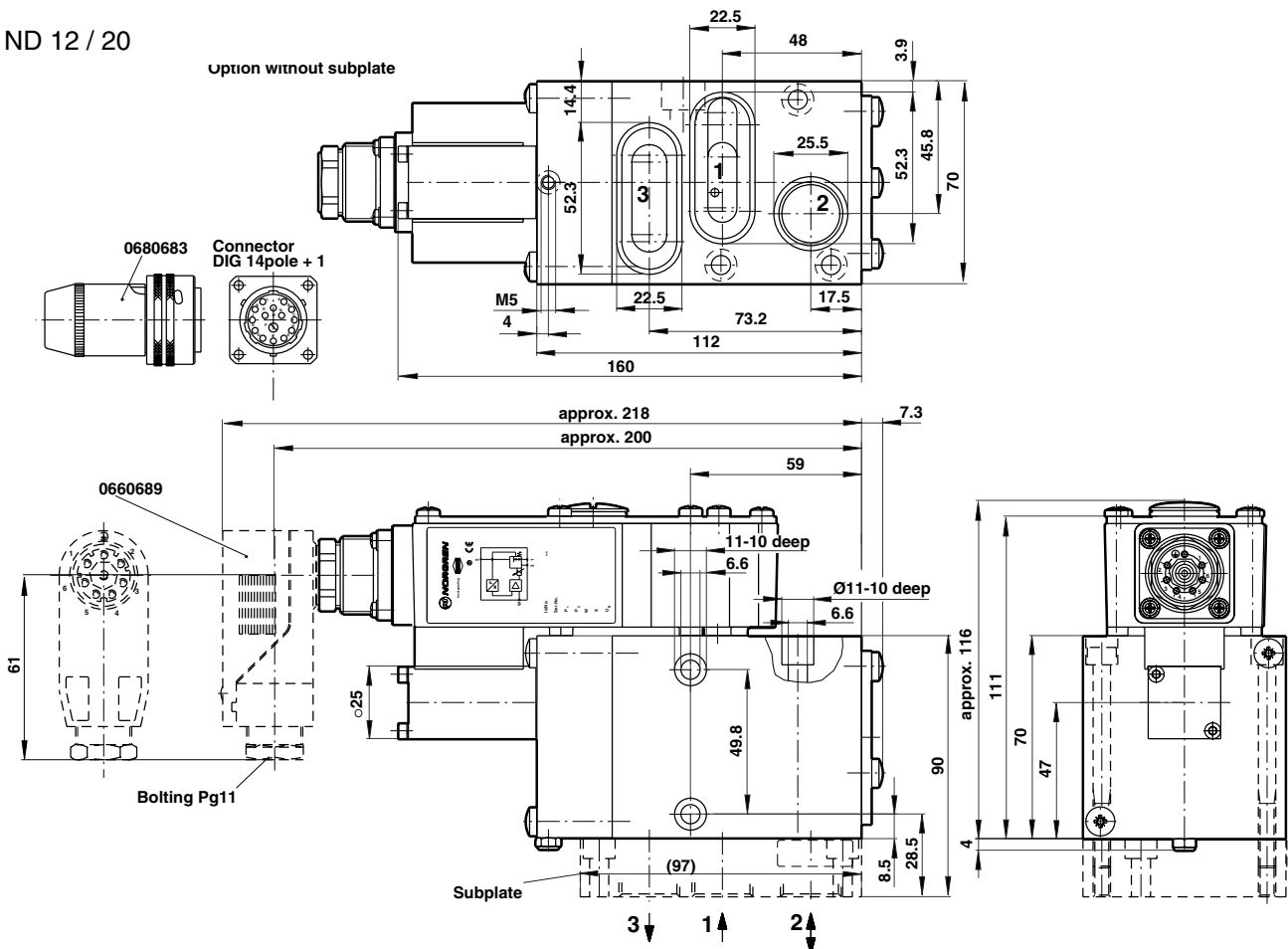



Basic dimensions Subplates (to be ordered separately)

Subplate G 1/8 for ND 2
Type: **0542845**

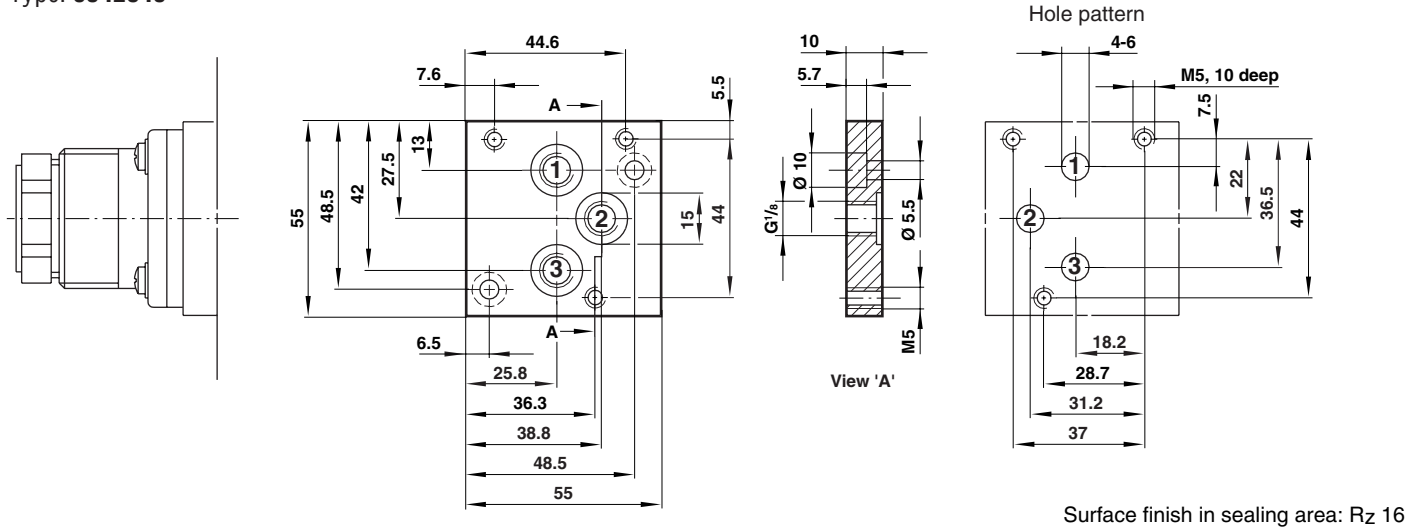

Subplate G 1/8 for ND 4
Type: **0542848**

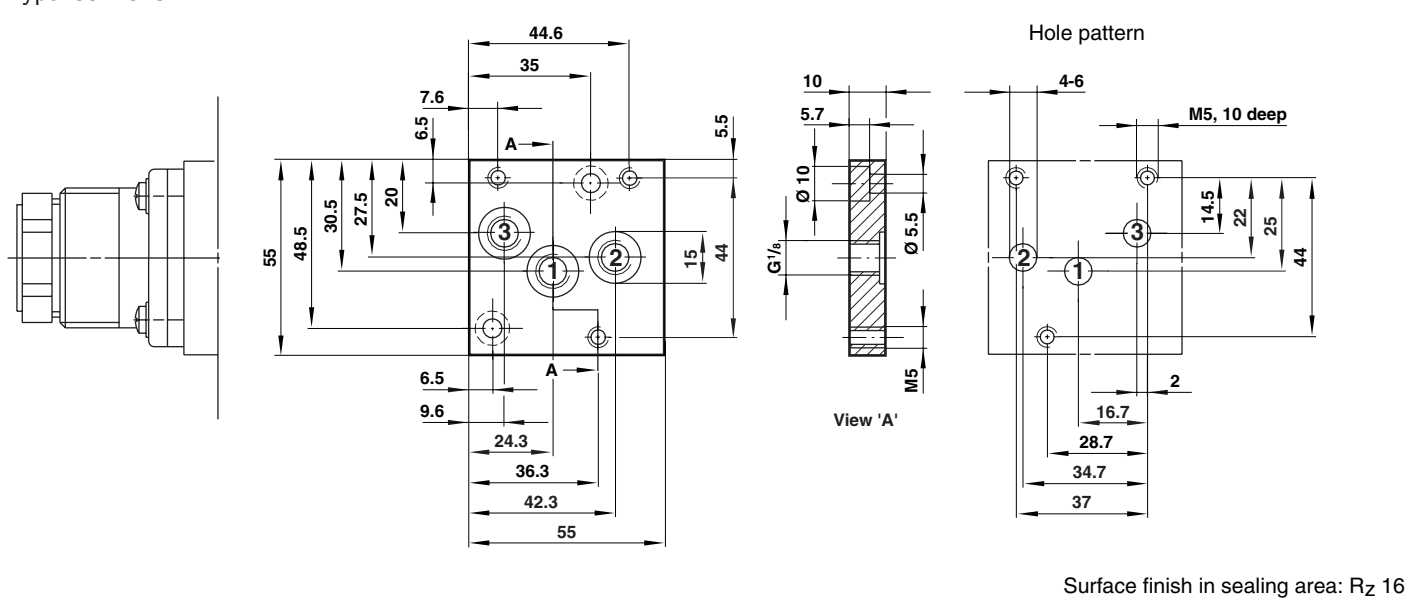



Basic dimensions Subplates (to be ordered separately)

Subplate G 1/4 for ND 8
 Type: **0542636**

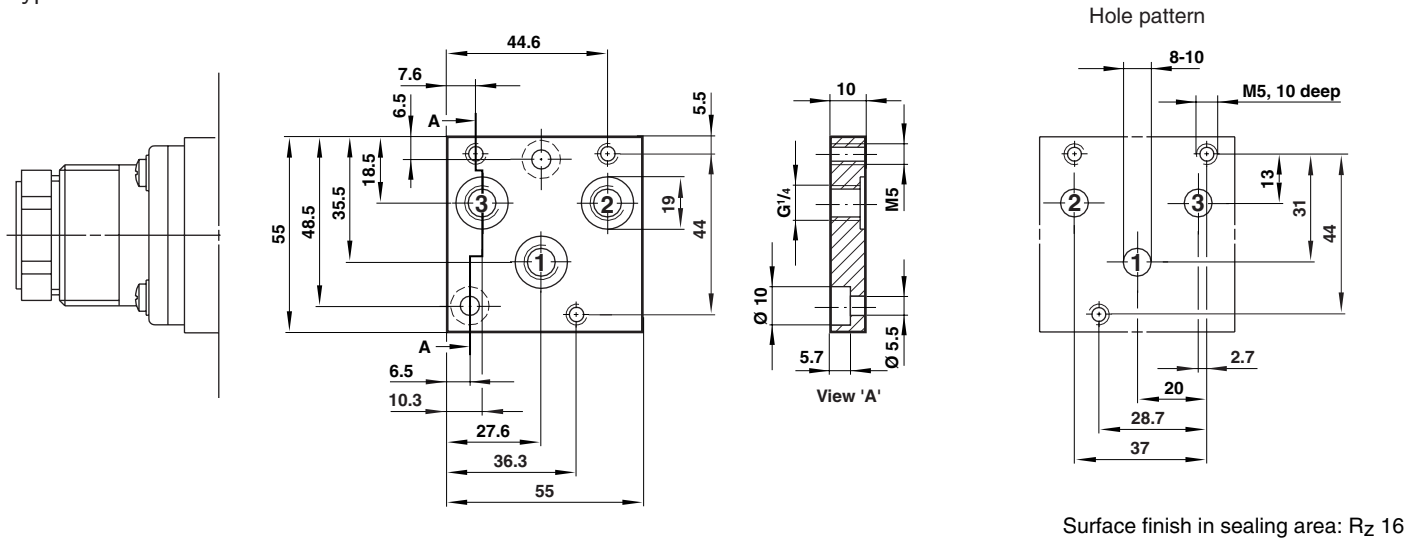

Subplate G 3/8 for ND 8
 Type: **0543705**

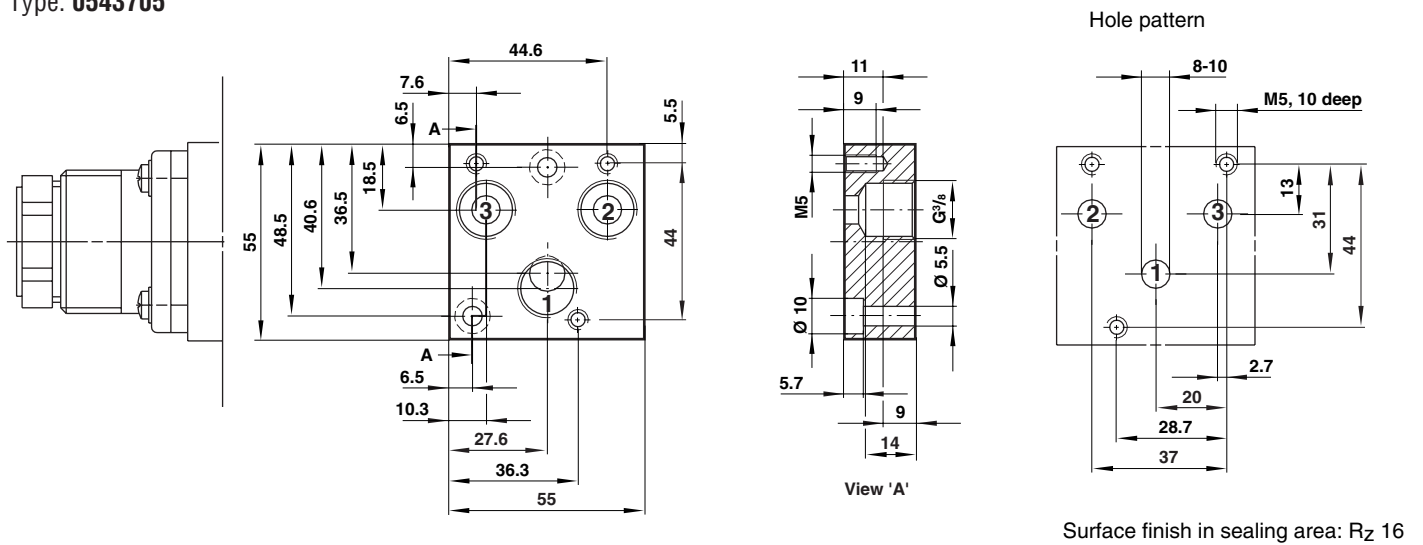



Basic dimensions Subplates (to be ordered separately)

G 1/2 Subplate for ND 12
Type: 0542814

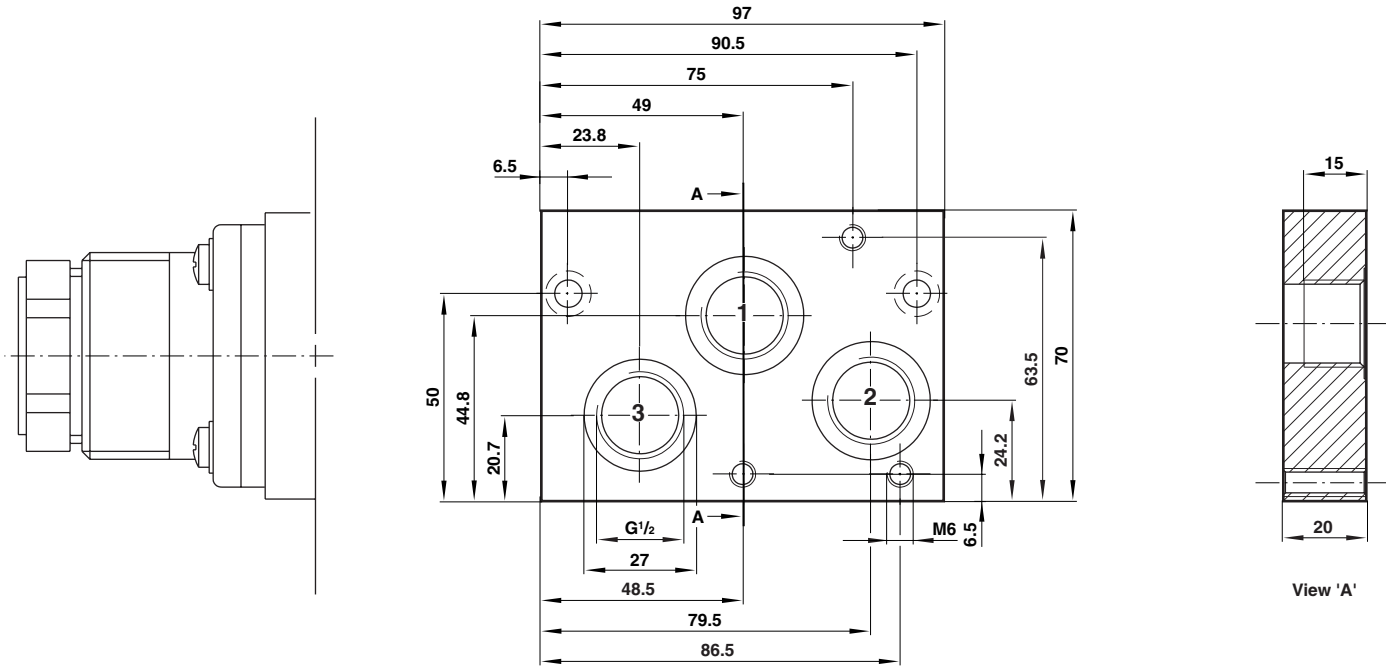

Hole pattern

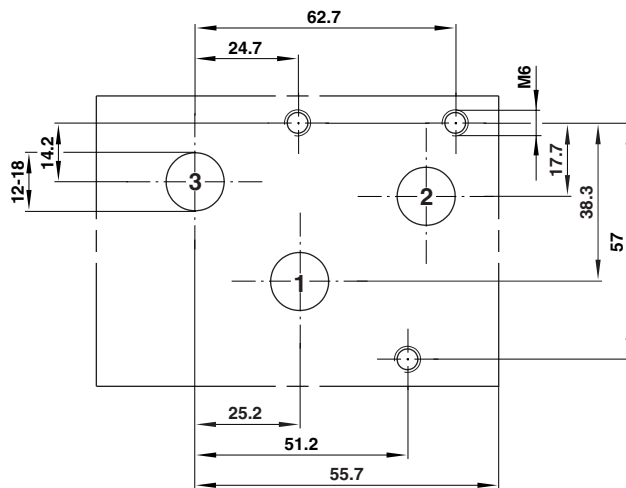

Surface finish in sealing area: Rz 16



Basic dimensions Subplates (to be ordered separately)

G 3/4 Subplate for ND 20

Type: **0542840**

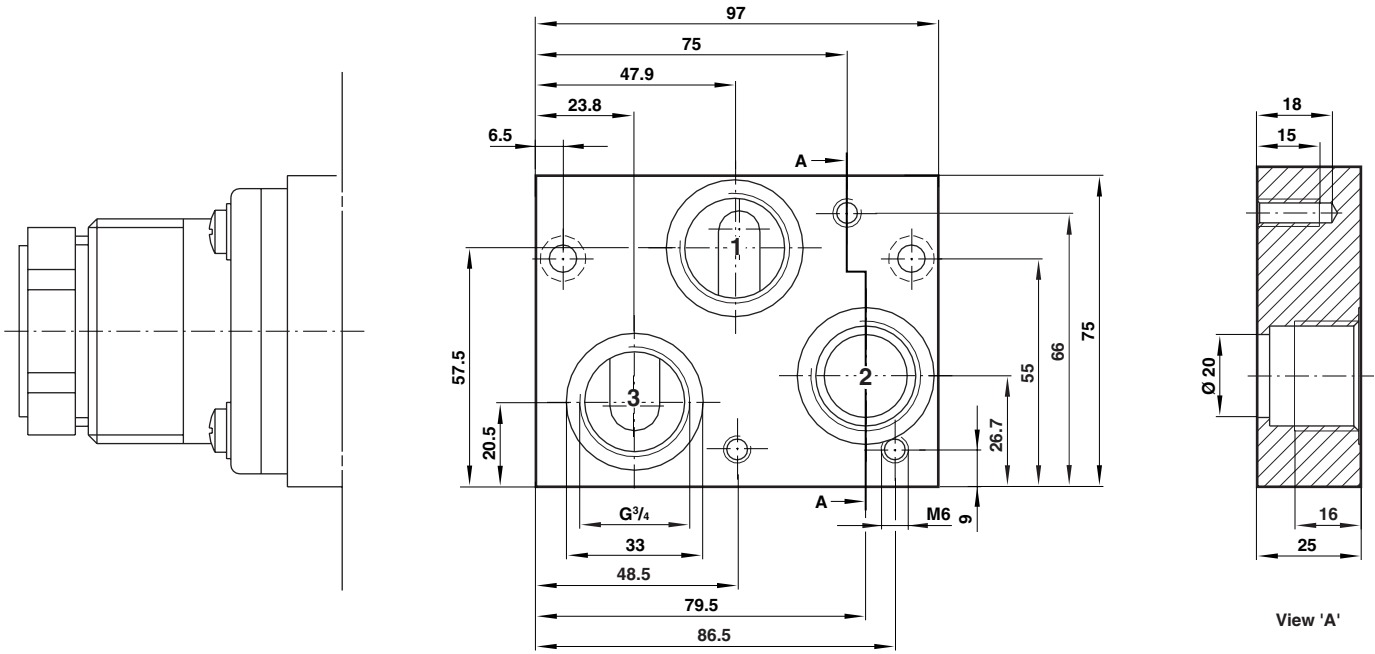

Hole pattern

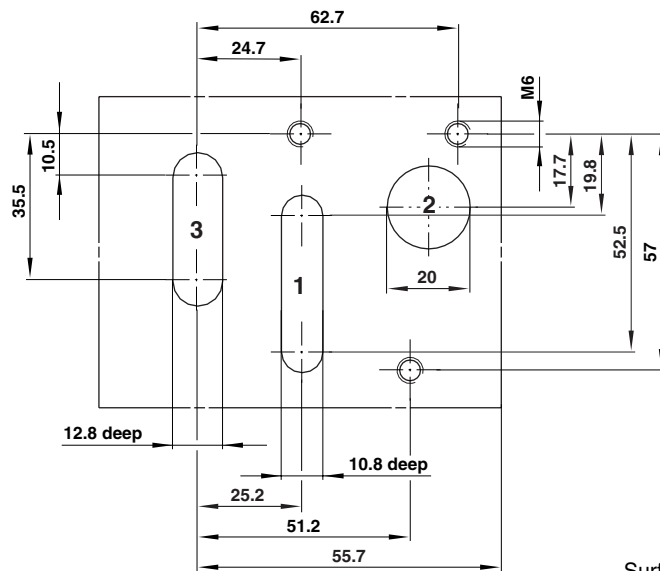

Surface finish in sealing area: Rz 16



Instructions for pneumatic installation and commissioning

1. Operating pressure p_1

The operating pressure must be higher than the max. required set pressure at the valve outlet.
Recommended: ≥ 1 bar.

When switching off the operating pressure, the operating voltage should be disconnected as well.

2. Line cross section

Cross section of supply line to 1 (P) should be larger than the nominal width of the valve.

Cross section of the working line to 2 (A) should be of the same size but at all events larger than the nominal width of the valve.

Air at the exhaust port 3 (R) must be discharged without pressure.

3. Combination with other units

3.1 Units connected upstream

(e.g. pressure sensors) Flow rate must be larger than that of the proportional valve.

3.2 Units connected downstream

(e.g. pilot valves) Same flow rate, but at any rate larger than that of the proportional valve.

4. Mounting place

As close as possible to the consuming device.

5. VERY IMPORTANT !

Before mounting the valve on the connection plate, the pneumatic lines must be blown out and freed from mounting residues.

Instructions for electrical installation

1. Voltage supply

Voltage supply 18 ... 32 V (incl. residual ripple) excess voltage may destroy the electronic system!

2. Avoidance of interferences

2.1 Screening

In order to prevent interferences by electric fields, screened lines must be used. The screen must be connected to PE (see circuit diagram)

2.2 Laying of cables

Supply and signalling lines shall not be laid in parallel to power mains or high-voltage lines.

3. Line cross section

According to VDE 01134.

Zero potentials

For zero potentials (0 V), the supply voltage and the set point signal, two separate wires must be used in order to prevent distortion of the set points.

Warning

These products are intended for use in industrial compressed air systems only. Do not use these products where pressures and temperatures can exceed those listed under 'Technical Data'.

Before using these products with fluids other than those specified, for non-industrial applications, life-support systems, or other applications not within published specifications, consult NORGREN.

Through misuse, age, or malfunction, components used in fluid power systems can fail in various modes. The system designer is warned to consider the failure modes of

General

Repairs and servicing

Do not attempt to repair the product by yourself.

After repair tasks, certain adjustments and test procedures have to be performed, which can only be done by qualified and authorised personnel. Products in need of repair may be sent to the following address:

IMI Norgren Herion Fluidtronic GmbH & Co. KG
Stuttgarter Straße 120, D-70736 Fellbach

Tel.: +49 (0) 711 / 52 09 -0
Fax: +49 (0) 711 / 52 09 -614

Abroad:

Your local representative dealer or agent will forward the product to the manufacturer for repair.

Please indicate a description of the error, malfunction or failure with the product you send in for repair. You should always state the serial number and the purchase date.

For servicing and repairing the products, we can offer experienced and qualified personnel. In case you need our assistance, please contact the following address:

IMI Norgren Herion Fluidtronic GmbH & Co. KG
D-70731 Fellbach

Tel.: +49 (0) 711 / 52 09 -0
Fax: +49 (0) 711 / 52 09 -614

Abroad:

Your local representative dealer or agent.

Transport, storage, default setting, cleaning

The product can only be transported and stored in the original Norgren Herion packaging which ensures suitable protection against mechanical damage.

The product is shipped in a ready-to-operate-state (default settings). After correct installation, it is ready for use.

In case it is necessary to clean product, we recommend sending it back to the manufacturer. The correct address can be found under repairs and servicing.

all component parts used in fluid power systems and to provide adequate safeguards to prevent personal injury or damage to equipment in the event of such failure.

System designers must provide a warning to end users in the system instructional manual if protection against a failure mode cannot be adequately provided.

System designers and end users are cautioned to review specific warnings found in instruction sheets packed and shipped with these products where applicable.