

3-way proportional pressure control valve
Electronic closed loop control
Nominal diameter 6

Compact and lightweight design

Control from 0 bar

Free of self heating

Indirect controlled 3-way proportional pressure control valve

Visual function display (optional)

Field bus capable as part of a valve island

Variable connection block technology

RoHS compliant

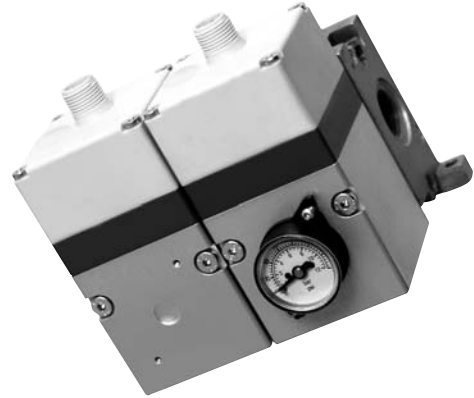

Technical data

Medium:

Filtered (30 µm min), unlubricated and condensate-free compressed air

Fluid temperature:

-5 ... +50°C (no condensation permitted)

Ambient:

Valve series is designed for indoor use at normal industrial ambient

Ambient temperature:

0 ... +50°C

Air supply must be dry enough to avoid ice formation at temperatures below +2°C

Degree of protection:

IP 65, M12-variant with connected plug

Connection:

Flange version with connecting plate G1/4

Pressure range:

Operating pressure P1 max.: 11 bar

Operating pressure P2:

0 ... 10 bar

Flow:

Max. 1600 NI/min., Flowrate see characteristics

Air consumption:

< 1,5 NI/min.

Tolerance:

Linearity: < 2,5 % Standard, < 0,5 % Precision

Control accuracy:

< 0,1 %

Hysteresis:

< 0,2 %

Repeat accuracy:

< 0,2 % (p2 max.)

Valves should not be used as an alternative to blocking or exhaust valves within a safety system.

Electromagnetic compatibility: (EMV):

Immunity EN 61000-6-2

Emission EN 61000-6-4

Material:

Valve housing: Plastic

Fluid affected parts: Brass, plastic, spring steel, elastomer

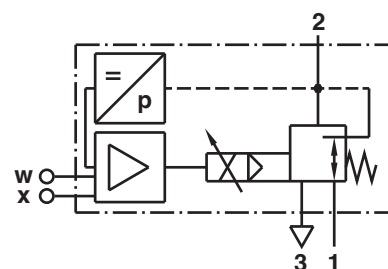

Electrical parameters

Supply voltage	24 V d.c. ± 10 %
Residual ripple	max. 10 %
Current consumption	30 mA
Capacity	0,7 W

Inputs (signal) 'w'

Voltage signal U _E	0 to 10 V d.c.
Input resistance R _E	> 55 KΩ
Current signal I _E	4 to 20 mA
Burden	500 Ω
Max. input voltage	11 V d.c.

Outputs (signal) 'x'

Voltage signal of pneumatic output pressure U _A	0 to 10 V d.c. = 0 to max. p ₂
Output current max. I _A	1 mA

Pneumatic parameters

Inlet pressure p ₁ max.	11 bar
Outlet pressure p ₂ max.	10 bar
Flow	see characteristics

Option selector

VPPC10BC★11K★000

Set point	Substitute	Linearity	Substitute
0 ... 10 V	1	Standard	E
4 ... 20 mA	4	Precision	P

Standard models (others on request)

Outlet pressure (bar)	Set point input	Linearity	Model
0 ... 10	0 ... 10 V	Standard	VPPC10BC111KE000
0 ... 10	0 ... 10 V	Precision	VPPC10BC111KP000
0 ... 10	4 ... 20 mA	Standard	VPPC10BC411KE000

Connection plates and Accessories

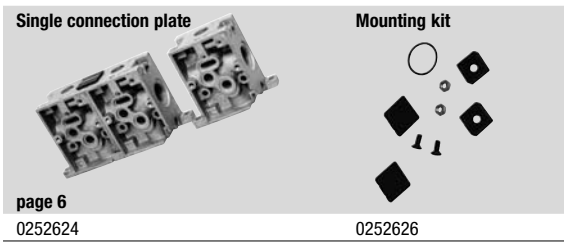

Connecting plugs

page 7	page 7	Model
M12x1; 5 pin; 5 m, 5 x 0,34 mm ² , 90°		0250081
M12x1; 5 pin; 10 m, 5 x 0,34 mm ² , 90°		0250472
M12x1; 5 pin; 5 m, 5 x 0,34 mm ² , straight		0523822
M12x1; 5 pin; wireable, straight		0252563
M12x1; 5 pin; wireable, 90°		0252543

Electrical diagram

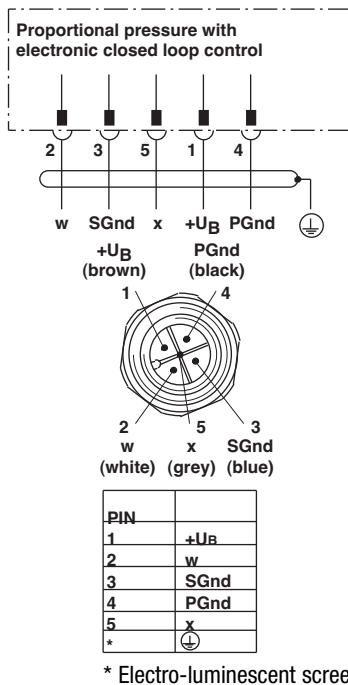

Pneumatic characteristic curves

Static characteristics

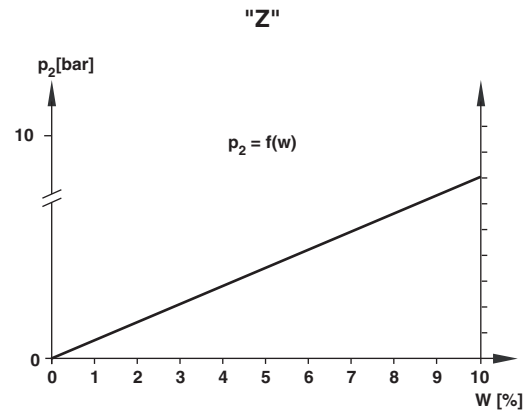
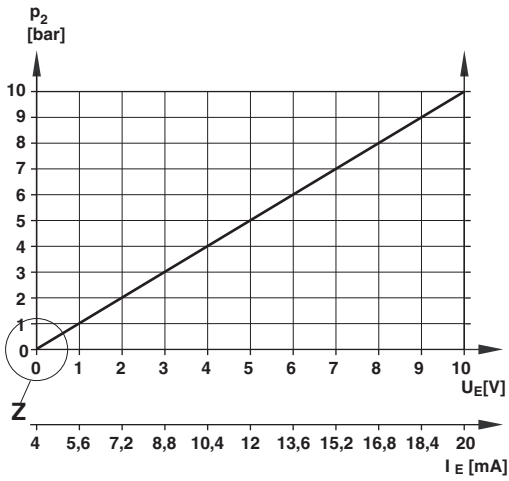

Flow rate characteristics

Flow from 1 to 2, Inlet pressure 10 bar

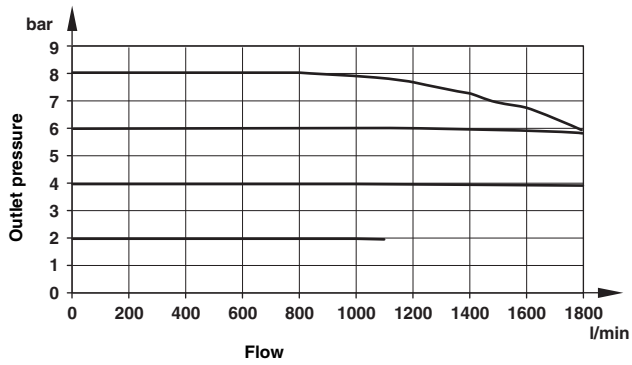

Flow from 1 to 2, Inlet pressure 7 bar

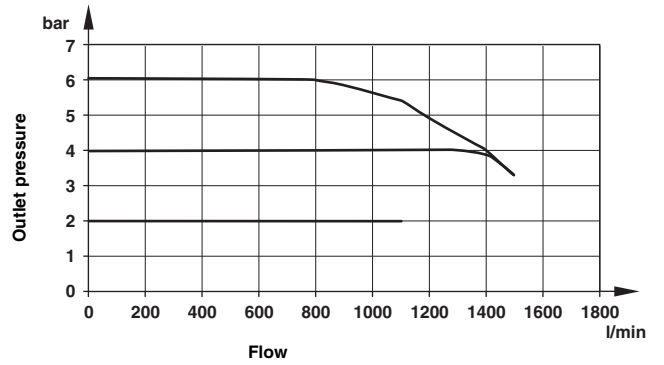

Flow from 2 to 3

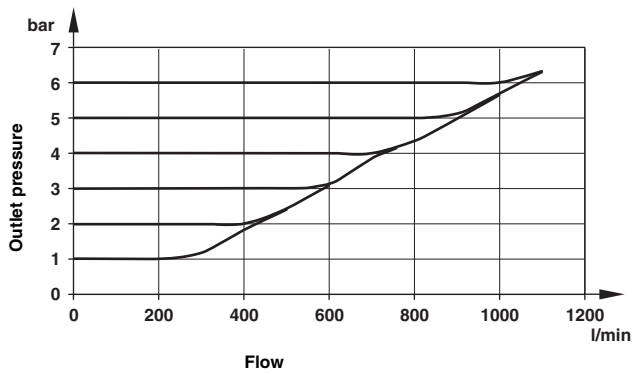

Basic dimensions

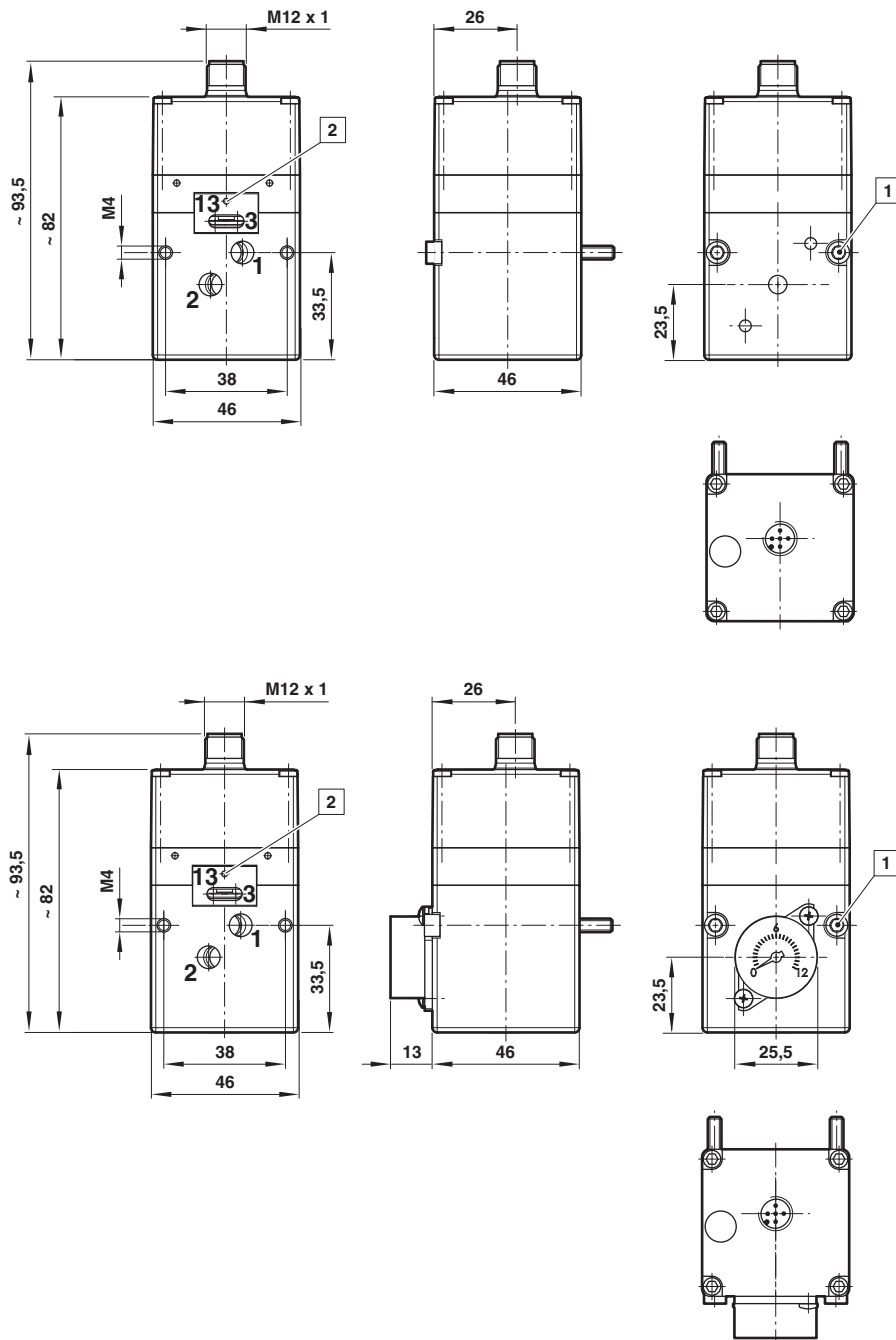

- 1** Mounting screws (supplied with unit)
- 2** Exhaust position (do not obstruct)

Single connection plate (option to use as a manifold sub-base)

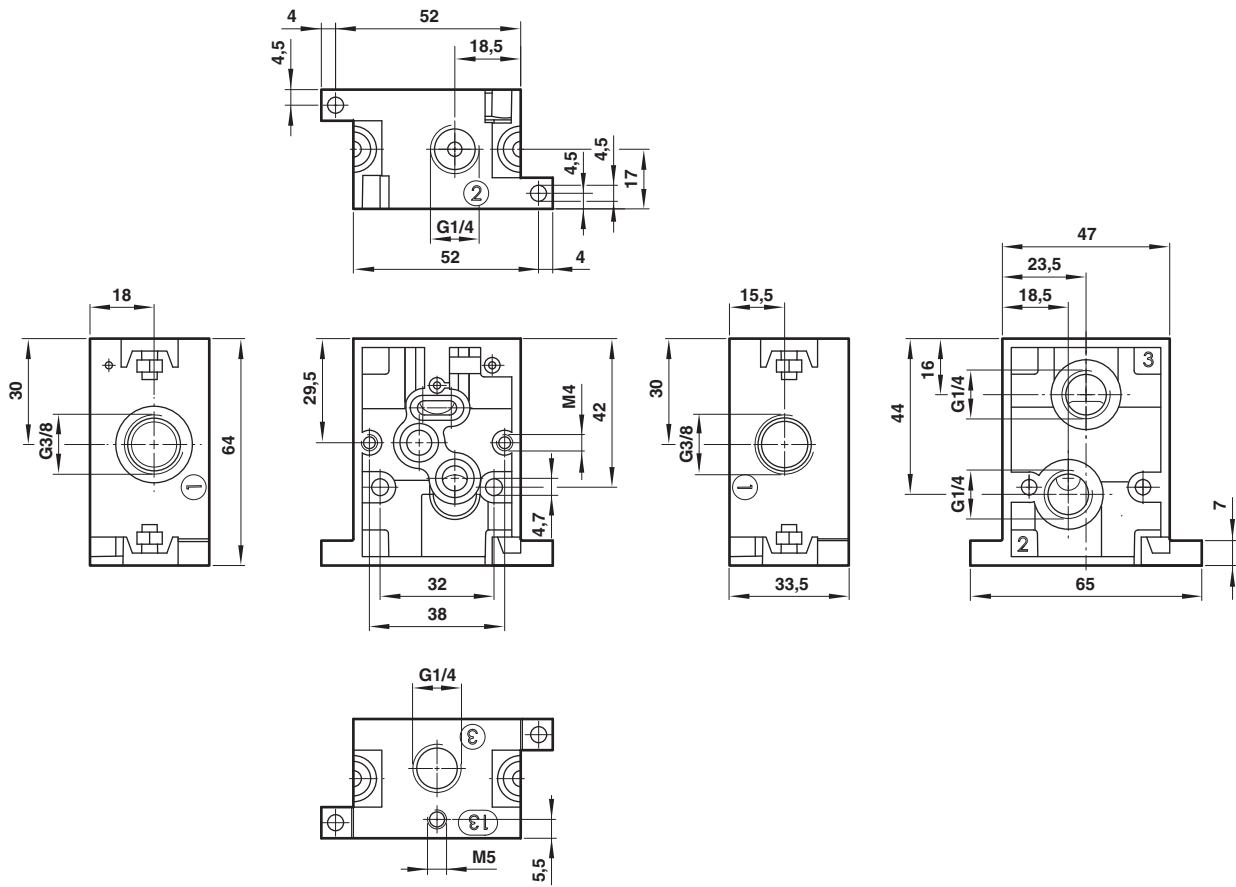

Connector

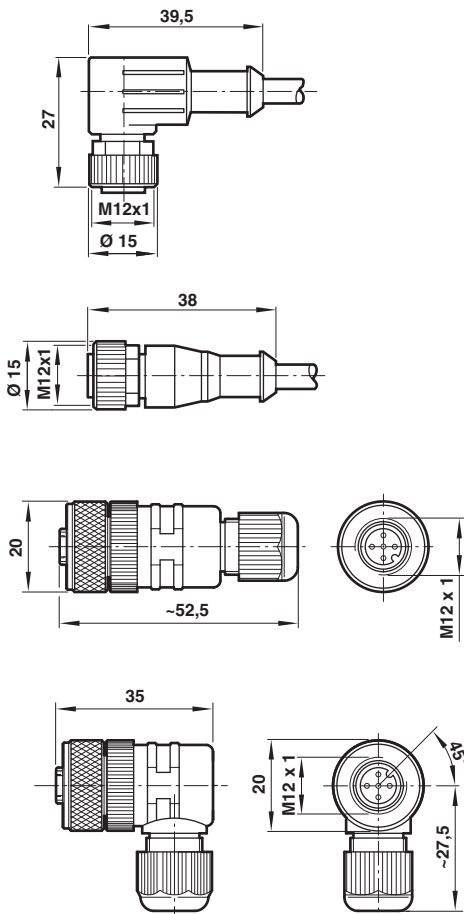

Connector, 90°

M12 x 1, 5 pin, female, A coded and 5 m cable length
Model: 0250081

M12 x 1, 5 pin, female, A coded and 10 m cable length
Model: 0250472

Connector, straight

M12 x 1, 5 pin, female, A coded and 5 m cable length
Model: 0523822

Connector, straight

M12 x 1, 5 pin, female, A coded
Model: 0252563

Connector, 90°

M12 x 1, 5 pin, female, A coded
Model: 0252543

Warning

These products are intended for use in industrial compressed air systems only. Do not use these products where pressures and temperatures can exceed those listed under 'Technical Data'.

Before using these products with fluids other than those specified, for non-industrial applications, life-support systems, or other applications not within published specifications, consult NORGREN.

Through misuse, age, or malfunction, components used in fluid power systems can fail in various modes.

The system designer is warned to consider the failure modes of all component parts used in fluid power systems and to provide adequate safeguards to prevent personal injury or damage to equipment in the event of such failure.

System designers must provide a warning to end users in the system instructional manual if protection against a failure mode cannot be adequately provided.

System designers and end users are cautioned to review specific warnings found in instruction sheets packed and shipped with these products.