

- > **Sub-base mounted, ISO 5599-1 sizes 1, 2, 3 or 4**
- > **Steel reinforced main seals**
- > **16 bar and 10 bar CNOMO solenoid pilots with locking or non-locking manual override**
- > **Low power coils (1,5W)**
- > **Wide range of sub-bases and accessories**

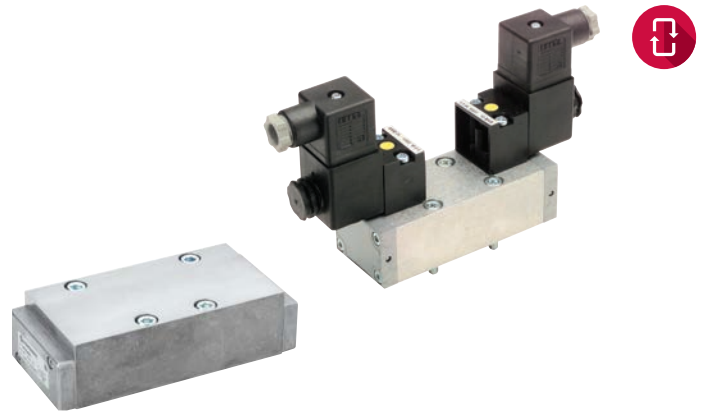

### Technical features

**Medium:**

Compressed air, 40 µm filtered, lubricated or non-lubricated

**Operation:**

Spool valve, solenoid pilot or air pilot actuated

**Mounting:**

On sub-bases

**Sizes:**

ISO 1, 2, 3 and 4

**Maximum operating pressure:**

Solenoid pilot actuated valves  
10 bar (145 psi)

Air pilot actuated valves and solenoid pilot actuated valves

16 bar (232 psi)

Details of minimum and maximum pilot pressure see overleaf

**Ambient/Media temperature:**

Solenoid pilot actuated valves  
-15 ... +50°C (+5 ... +122°F)

Air pilot actuated valves

-15 ... +80°C (+5 ... +176°F)

Air supply must be dry enough to avoid ice formation at temperatures below +2°C (+35°F).







**Materials:**

Body: die cast aluminium  
Spool: light alloy aluminium  
Seals: NBR

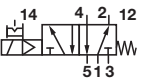
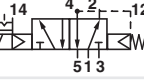
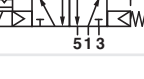
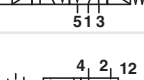
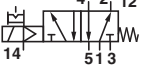
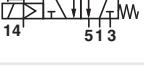
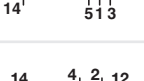
### Electrical details for solenoid operators

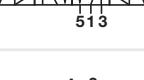
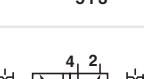
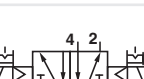
<b>Voltage tolerance</b>	± 10%		
<b>Rating</b>	100% continuous duty		
<b>Inlet orifice</b>	1,0 mm		
<b>Electrical connection (corresponding to chosen coil)</b>	EN 175301-803 - Form A, 30 mm		
	EN 175301-803 - Form B, 22 mm		
	Industrial Standard, 22 mm		
<b>Solenoid coil</b>	May be rotated at 90° intervals		
<b>Manual override</b>	10 bar version	Turn to lock (plastic)	# = 60
		Push only (plastic)	# = 61
	16 bar version	Turn to lock (plastic)	# = 60
		Push only (brass)	# = 61
<b>Protection class</b>	IP 65 (with sealed plug)		

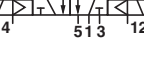
### 5/2 Solenoid pilot actuated valves – 10 bar models

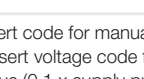

Symbol	ISO size	Operator/return	Pilot supply	Flow (l/min)	Operating pressure (bar)	Pilot pressure (bar)	Weight (kg)	Drawing No.	Model
	1	Solenoid/spring	Internal	1200	2 ... 10	—	0,45	1	UM/22152/122/6#/*1)
	2	Solenoid/spring and air	Internal	2130	2,5 ... 10	—	0,70	3	UM/22253/172/6#/*1)
	3	Solenoid/spring and air	Internal	4150	2,5 ... 10	—	1,00	3	UM/22354/172/6#/*1)
	4	Solenoid/spring and air	Internal	5660	2,5 ... 10	—	1,27	3	UM/22456/172/6#/*1)
	1	Solenoid/spring	External	1200	-0,9 ... 16	2,3 *2) ... 10	0,45	1	UM/22152/22/6#/*1)
	2	Solenoid/spring	External	2130	-0,9 ... 16	1,8 *2) ... 10	0,70	3	UM/22253/22/6#/*1)
	3	Solenoid/spring	External	4150	-0,9 ... 16	1,8 *2) ... 10	1,00	3	UM/22354/22/6#/*1)
	4	Solenoid/spring	External	5660	-0,9 ... 16	1,8 *2) ... 10	1,27	3	UM/22456/22/6#/*1)
	1	Solenoid/ solenoid	Internal	1200	2 ... 10	—	0,59	2	UM/22152/123/6#/*1)
	2	Solenoid/ solenoid	Internal	2130	2 ... 10	—	0,84	4	UM/22253/123/6#/*1)
	3	Solenoid/ solenoid	Internal	4150	2 ... 10	—	1,14	4	UM/22354/123/6#/*1)
	4	Solenoid/ solenoid	Internal	5660	2 ... 10	—	1,41	4	UM/22456/123/6#/*1)
	1	Solenoid/ solenoid	External	1200	-0,9 ... 16	2,3 *2) ... 10	0,59	2	UM/22152/23/6#/*1)
	2	Solenoid/ solenoid	External	2130	-0,9 ... 16	1,5 *2) ... 10	0,84	4	UM/22253/23/6#/*1)
	3	Solenoid/ solenoid	External	4150	-0,9 ... 16	1,5 *2) ... 10	1,14	4	UM/22354/23/6#/*1)
	4	Solenoid/ solenoid	External	5660	-0,9 ... 16	1,5 *2) ... 10	1,41	4	UM/22456/23/6#/*1)

# Insert code for manual override: 0 = turn to lock, 1 = push only

\*1) Insert voltage code from page 2. Standard are: '13J' for 24 V d.c. or '19J' for 240 V a.c.

\*2) plus (0,1 x supply pressure)

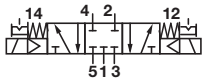
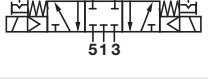
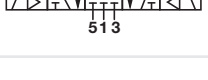
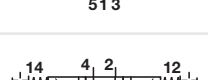
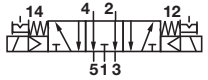
### 5/3 Solenoid pilot actuated valves – 10 bar models

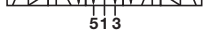
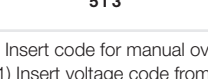
Symbol	ISO size	Function	Operator/return	Pilot supply	Flow (l/min)	Operating pressure (bar)	Weight (kg)	Drawing No.	Model
	1	APB	Solenoid/ solenoid	Internal	660	2,5 ... 10	0,59	2	UM/22152/6123/6#/*1)
	2	APB	Solenoid/ solenoid	Internal	1520	2,8 ... 10	0,84	4	UM/22253/6123/6#/*1)
	3	APB	Solenoid/ solenoid	Internal	3750	2,8 ... 10	1,14	4	UM/22354/6123/6#/*1)
	4	APB	Solenoid/ solenoid	Internal	5490	2,8 ... 10	1,41	4	UM/22456/6123/6#/*1)
	1	COE	Solenoid/ solenoid	Internal	660	2,5 ... 10	0,59	2	UM/22162/6123/6#/*1)
	2	COE	Solenoid/ solenoid	Internal	1520	2,8 ... 10	0,84	4	UM/22263/6123/6#/*1)
	3	COE	Solenoid/ solenoid	Internal	3750	2,8 ... 10	1,14	4	UM/22364/6123/6#/*1)
	4	COE	Solenoid/ solenoid	Internal	5490	2,8 ... 10	1,41	4	UM/22466/6123/6#/*1)

# Insert code for manual override: 0 = turn to lock, 1 = push only

\*1) Insert voltage code from page 2. Standard are: '13J' for 24 V d.c. or '19J' for 240 V a.c.

Function: APB = All Ports Blocked; COE = Centre Open Exhaust

### Voltage codes and spare coils for 10 bar models

22 mm coil for connector interface acc. to industrial standard				
	Voltage	Power Inrush/Hold	Model	Code
	12 V d.c.	2 W	QM/48/12J/21	12J
	24 V d.c.	2 W	QM/48/13J/21	13J
	24 V 50/60 Hz	4/2,5 VA	QM/48/14J/21	14J
	48 V 50/60 Hz	4/2,5 VA	QM/48/16J/21	16J
	110/120 V 50/60 Hz	4/2,5 VA	QM/48/18J/21	18J
	220/240 V 50/60 Hz	6/5,0 VA	QM/48/19J/21	19J



22 mm coil for connector interface acc. EN 175 301-803, form B				
	Voltage	Power Inrush/Hold	Model	Code
	12 V d.c.	2 W	V10626-A12L	12L
	24 V d.c.	2 W	V10626-A13L	13L
	24 V 50/60 Hz	4/2,5 VA	V10626-A14L	14L
	48 V 50/60 Hz	4/2,5 VA	V10626-A16L	16L
	110/120 V 50/60 Hz	4/2,5 VA	V10626-A18L	18L
	220/240 V 50/60 Hz	6/5,0 VA	V10626-A19L	19L

30 mm coil for connector interface acc. EN 175 301-803, form A				
	Voltage	Power Inrush/Hold	Model	Code
	12 V d.c.	1,5 W	V10633-A22N	22N
	24 V d.c.	1,5 W	V10633-A23N	23N
	24 V 50/60 Hz	3/2 VA	V10633-A24N	24N
	48 V 50/60 Hz	3/2 VA	V10633-A26N	26N
	110/120 V 50/60 Hz	3/2 VA	V10633-A28N	28N
	220/240 V 50/60 Hz	3/2 VA	V10633-A29N	29N

### Connector plugs - ordered separately

Industrial standard 22 mm 2-pole + PE	22 mm, EN 175301-803 (DIN 43650 B) Form B 2-pole + PE	30 mm, EN 175301-803 (DIN 43650 B) Form A 2-pole + PE
		
0657868	0680003	0570275

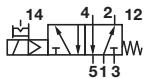
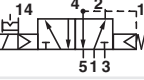
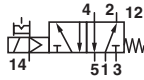
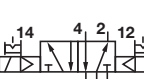

**5/2 Solenoid pilot actuated valves – 16 bar models**

Symbol	ISO size	Operator/return	Pilot supply	Flow (l/min)	Operating pressure (bar)	Pilot pressure (bar)	Weight (kg)	Drawing No.	Model
	1	Solenoid/spring	Internal	1200	2 ... 16	—	0,45	1	UM/22152/122/8#/*1)
	2	Solenoid/spring and air	Internal	2130	2,5 ... 16	—	0,70	3	UM/22253/172/8#/*1)
	3	Solenoid/spring and air	Internal	4150	2,5 ... 16	—	1,00	3	UM/22354/172/8#/*1)
	4	Solenoid/spring and air	Internal	5660	2,5 ... 16	—	1,27	3	UM/22456/172/8#/*1)
	1	Solenoid/spring	External	1200	-0,9 ... 16	2,3 *2) ... 16	0,45	1	UM/22152/22/8#/*1)
	2	Solenoid/spring	External	2130	-0,9 ... 16	1,8 *2) ... 16	0,70	3	UM/22253/22/8#/*1)
	3	Solenoid/spring	External	4150	-0,9 ... 16	1,8 *2) ... 16	1,00	3	UM/22354/22/8#/*1)
	4	Solenoid/spring	External	5660	-0,9 ... 16	1,8 *2) ... 16	1,27	3	UM/22456/22/8#/*1)
	1	Solenoid/ solenoid	Internal	1200	2 ... 16	—	0,59	2	UM/22152/123/8#/*1)
	2	Solenoid/ solenoid	Internal	2130	2 ... 16	—	0,84	4	UM/22253/123/8#/*1)
	3	Solenoid/ solenoid	Internal	4150	2 ... 16	—	1,14	4	UM/22354/123/8#/*1)
	4	Solenoid/ solenoid	Internal	5660	2 ... 16	—	1,41	4	UM/22456/123/8#/*1)
	1	Solenoid/ solenoid	External	1200	-0,9 ... 16	2,3 *2) ... 16	0,59	2	UM/22152/23/8#/*1)
	2	Solenoid/ solenoid	External	2130	-0,9 ... 16	1,5 *2) ... 16	0,84	4	UM/22253/23/8#/*1)
	3	Solenoid/ solenoid	External	4150	-0,9 ... 16	1,5 *2) ... 16	1,14	4	UM/22354/23/8#/*1)
	4	Solenoid/ solenoid	External	5660	-0,9 ... 16	1,5 *2) ... 16	1,41	4	UM/22456/23/8#/*1)

# Insert code for manual override: 0 = turn to lock, 1 = push only \* Insert voltage code from page 2. Standard are: '33N' for 24 V d.c. or '89N' for 240 V a.c.

\*2) plus (0,1 x supply pressure)

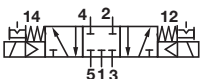
**5/3 Solenoid pilot actuated valves – 16 bar models**

Symbol	ISO size	Function	Operator/return	Pilot supply	Flow (l/min)	Operating pressure (bar)	Weight (kg)	Drawing No.	Model
	1	APB	Solenoid/ solenoid	Internal	660	2,5... 16	0,59	2	UM/22152/6123/8#/*1)
	2	APB	Solenoid/ solenoid	Internal	1520	2,8 ... 16	0,84	4	UM/22253/6123/8#/*1)
	3	APB	Solenoid/ solenoid	Internal	3750	2,8 ... 16	1,14	4	UM/22354/6123/8#/*1)
	4	APB	Solenoid/ solenoid	Internal	5490	2,8 ... 16	1,41	4	UM/22456/6123/8#/*1)
	1	COE	Solenoid/ solenoid	Internal	660	2,5 ... 16	0,59	2	UM/22162/6123/8#/*1)
	2	COE	Solenoid/ solenoid	Internal	1520	2,8 ... 16	0,84	4	UM/22263/6123/8#/*1)
	3	COE	Solenoid/ solenoid	Internal	3750	2,8 ... 16	1,14	4	UM/22364/6123/8#/*1)
	4	COE	Solenoid/ solenoid	Internal	5490	2,8 ... 16	1,41	4	UM/22466/6123/8#/*1)

# Insert code for manual override: 0 = turn to lock, 1 = push only

\* Insert voltage code from page 2. Standard are: '33N' for 24 V d.c. or '89N' for 240 V a.c.

Function: APB = All Ports Blocked, COE = Centre Open Exhaust

**Voltage codes and spare coils for 16 bar models**

30 mm coil for connector interface acc. acc. EN 175 301-803, form A				
Voltage	Power	Inrush/Hold	Model	Code
12 V d.c.	4 W		V10633-A32N	32N
24 V d.c.	4 W		V10633-A33N	33N
110 V d.c.	4 W		V10633-A37N	37N
24 V a.c.	10/8 VA		V10633-A84N	84N
110/120 V 50/60 Hz	10/8 VA		V10633-A88N	88N
220/240 V 50/60 Hz	10/8 VA		V10633-A89N	89N

Other Voltages available on request.

**Connector plug - ordered separately**



**Option selector  
(solenoid actuated valves)**

UM/22\*\*\*\*/\*\*\*\*\*/\*\*\*/\*\*\*\*

ISO size	Substitute
1	1
2	2
3	3
4	4
Valve function	Substitute
5/2 monostable & bistable, 5/3 APB	5
5/3 COE only	6
Port size	Substitute
ISO 1 (1/4")	2
ISO 2 (3/8")	3
ISO 3 (1/2")	4
ISO 4 (3/4")	6

Voltage code	Substitute
For voltage code see tables on page 2	*)
Manual override	Substitute
Push and turn	0
Push only	1
Pressure	Substitute
10 bar	6
16 bar	8
Valve function	Substitute
5/2 Solenoid/spring, external pilot, monostable	22
5/2 Solenoid/Solenoid, external pilot, bistable	23
5/2 Solenoid/spring, internal pilot, monostable	122
5/2 Solenoid/Solenoid, internal pilot, bistable	123
5/2 Solenoid/airspring & spring, internal pilot, monostable	172
5/3 - APB & COE Solenoid/Solenoid, internal pilot, monostable	6123

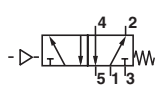
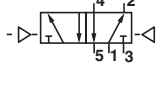
**5/2 Air pilot actuated valves – 16 bar models**

Symbol	ISO size	Operator/return	Flow (l/min)	Operating pressure (bar)	Pilot pressure (bar)	Weight (kg)	Drawing No.	Model
	1	Air/spring	1200	-0,9 ... 16	2,3 *2) ... 16	0,34	6	UM/22152/40
	2	Air/spring	2130	-0,9 ... 16	1,8 *2) ... 16	0,60	6	UM/22253/40
	3	Air/spring	4150	-0,9 ... 16	2,8 *2) ... 16	1,00	6	UM/22354/40
	4	Air/spring	5660	-0,9 ... 16	1,8 *2) ... 16	1,30	6	UM/22456/40
	1	Air/air	1200	-0,9 ... 16	1,0 *2) ... 16	0,34	5	UM/22152/3
	2	Air/air	2130	-0,9 ... 16	1,5 *2) ... 16	0,50	5	UM/22253/3
	3	Air/air	4150	-0,9 ... 16	1,5 *2) ... 16	0,90	5	UM/22354/3
	4	Air/air	5660	-0,9 ... 16	1,5 *2) ... 16	1,20	5	UM/22456/3

\*2) plus (0,1 x supply pressure)

**Standard version**

**5/3 Air pilot actuated valves – 16 bar models**

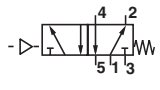
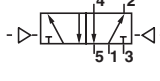
Symbol	ISO size	Operator/return	Flow (l/min)	Operating pressure (bar)	Pilot pressure (bar)	Weight (kg)	Drawing No.	Model
	1	Air/spring	1200	-0,9 ... 16	2,3 *2) ... 16	0,34	6	UM/22152/40
	2	Air/spring	2130	-0,9 ... 16	1,8 *2) ... 16	0,60	6	UM/22253/40
	3	Air/spring	4150	-0,9 ... 16	2,8 *2) ... 16	1,00	6	UM/22354/40
	4	Air/spring	5660	-0,9 ... 16	1,8 *2) ... 16	1,30	6	UM/22456/40
	1	Air/air	1200	-0,9 ... 16	1,0 *2) ... 16	0,34	5	UM/22152/3
	2	Air/air	2130	-0,9 ... 16	1,5 *2) ... 16	0,50	5	UM/22253/3
	3	Air/air	4150	-0,9 ... 16	1,5 *2) ... 16	0,90	5	UM/22354/3
	4	Air/air	5660	-0,9 ... 16	1,5 *2) ... 16	1,20	5	UM/22456/3

\*2) plus (0,1 x supply pressure)

Function: APB = All Ports Blocked; COE = Centre Open Exhaust

**Option selector  
(pilot actuated valves)**

UM/22\*\*\*\*/\*\*\*

ISO size	Substitute
1	1
2	2
3	3
4	4
Valve function	Substitute
5/2 monostable & bistable, 5/3 APB	5
5/3 COE only	6

Valve function	Substitute
5/2 Air/air, bistable	3
5/2 Air/air, bistable, priority port 14	33
5/2 Air/spring, monostable	40
5/3 - APB & COE Air/air, monostable	63
Port size	Substitute
ISO 1 (1/4")	2
ISO 2 (3/8")	3
ISO 3 (1/2")	4
ISO 4 (3/4")	6

**Sub-bases, end plates and blanking disc - VDMA 24345 sub-base options**

ISO size	Single station sub-base, Form A side ported		Single station sub-base Form B bottom ported		Modular sub-base Form C		Form D End plates		Blanking disc for VDMA sub-bases *1)	
	Page 8		Page 8		Page 8		Page 8		Page 9	
	ISO G thread	NPT thread	ISO G thread		ISO G thread	NPT thread	ISO G thread	NPT thread	ISO G thread	NPT thread
1	M/P19126 (1/4)	C/P19126 (1/4)	M/P19125 (1/4)		CQM/22152/3/21	239-238B	CQM/22152/3/22	239-289B	FP 8382	239-251
2	M/P19132 (3/8)	C/P19132 (3/8)	M/P19131 (3/8)		CQM/22253/3/21	239-242B	CQM/22253/3/22	239-291B	FP 8482	239-252
3	M/P19138 (1/2)	C/P19138 (1/2)	M/P19137 (1/2)		CQM/22354/3/21	239-246B	CQM/22354/3/22	239-293B	FP 8582	239-253
4	M/P19144 (3/4)		M/P19143 (3/4)		CQM/22456/3/21					

**Universal sub-base options for ISO G parallel threads only**

ISO size	Modular base with side, end and bottom ports open		Universal end plate, all ports blocked		Universal end plate, side ports open		Transition plate from ISO 1 » ISO 2		Blanking disk for ISO 1 and ISO 2	
	Page 10		Page 10		Page 10		Page 10		Page 10	
1	CQM/22152/3/27 (G1/4)		CQM/22152/28 (G1/4)		CQM/22152/3/31 (G1/4)		CQM/22152/3/29		M/P43173	
2	CQM/22253/3/27 (G3/8)		CQM/22153/28 (G3/8)		CQM/22253/3/31 (G3/8)		CQM/22152/3/29		M/P43174	

**Accessories for ISO G parallel and NPT threads**

ISO size	Blanking plate for VDMA and universal sub-bases		Transition plate for VDMA sub-bases		Silencer		Sandwich plate with check valves		Flow regulator plate, ports 3 and 5 regulated	
	Page 9		Page 9		Page 9		Page 12		Page 13	
1	CQM/22152/3/23		CQM/22152/3/24 (1 » 2)		0015510		FP7050		CQM/22152/3/26	
2	CQM/22253/3/23		CQM/22253/3/24 (2 » 3)				—		CQM/22253/3/26	
3	CQM/22354/3/23		FP8570 (1 » 3)				FP7070		CQM/22354/3/26	
4	CQM/22456/3/23		—		—		—		CQM/22456/3/26	

**Sandwich plates - ISO size 1 only, ISO sizes 2 and 3 on request**

ISO size	Single pressure regulator plate, port 1 regulated		Single pressure regulator plate, port 1 regulated		Single pressure regulator plate, port 2 regulated		Single pressure regulator plate, port 4 regulated		Double pressure regulator plate, port 2 & 4 regulated	
	Page 11		Page 11		Page 11		Page 11		Page 12	
1	V71010-KB1 (Regulator on side 14)		V71011-KB1 (Regulator on side 12)		V71012-KB2		V71012-KB3		V71012-KB4	

**Spares kit**

Model	Description
QM/22152/3/00	Spares Kit for ISO #1 Valves (UM/22152)
QM/22253/3/00	Spares Kit for ISO #2 Valves (UM/22253)
QM/22354/3/00	Spares Kit for ISO #3 Valves (UM/22354)
QM/22456/3/00	Spares Kit for ISO #4 Valves (UM/22456)

Drawings

Dimensions in mm  
Projection/First angle

5/2 Single solenoid valves ISO size 1

5/2 and 5/3 Double solenoid valves ISO size 1 

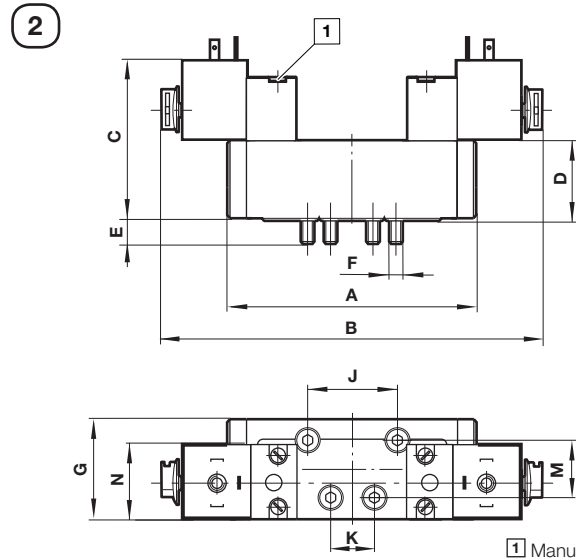
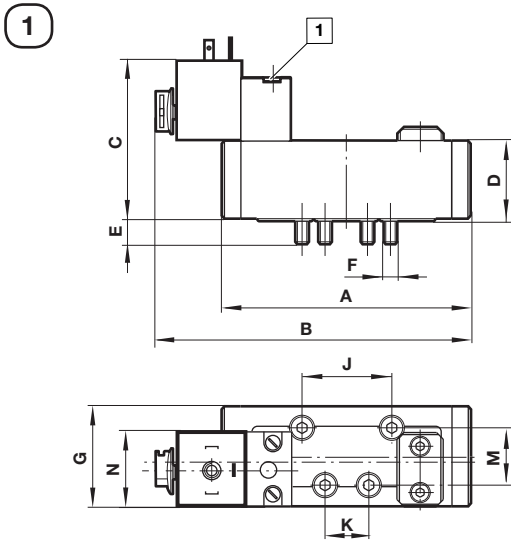

ISO size	A	B	C	D	E	F	G	J	K	M	N*
1	107	135	70	32	9	M5	42,5	36	18	28	22 or 30

ISO size	A	B	C	D	E	F	G	J	K	M	N*
1	107	168	70	32	9	M5	42,5	36	18	28	22 or 30

\* Illustrated with 30 mm coil

\* Illustrated with 30 mm coil

5/2 Single solenoid valves ISO size 2, 3 and 4

5/2 and 5/3 Double solenoid valves ISO size 2, 3 and 4

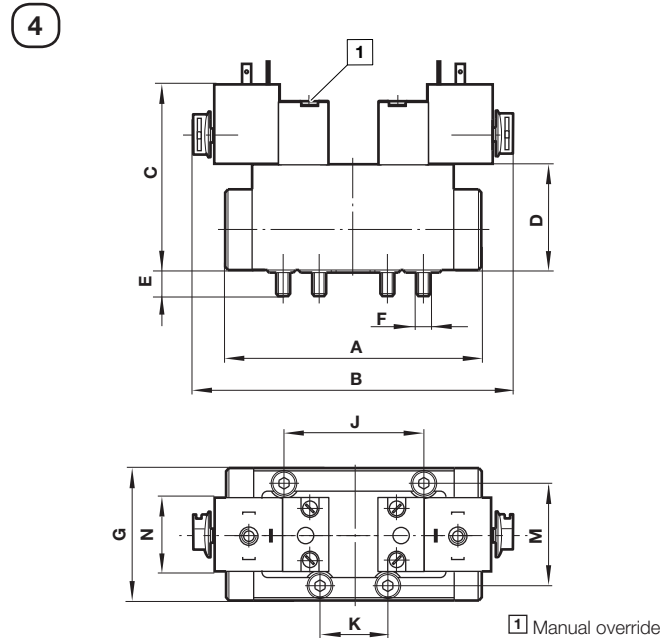
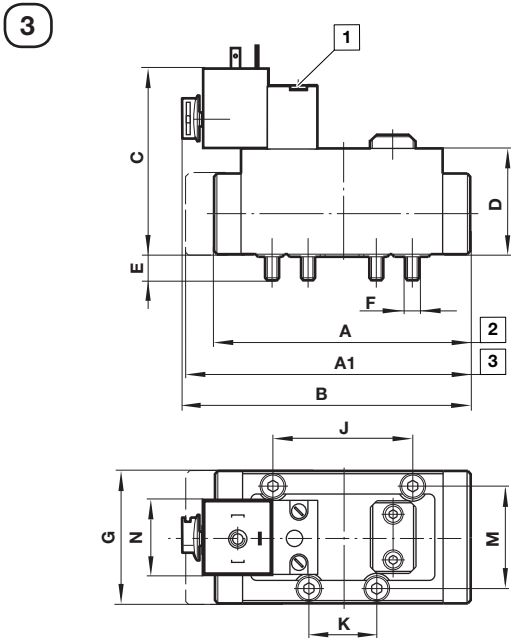



ISO size	A	A1	B	C	D	E	F	G	J	K	M	N*
2	106	124	125	83	45	9	M6	55	48	24	38	22 or 30
3	138	160	139	83	45	14	M8	68	64	32	48	22 or 30
4	177	187	152	83	45	14	M8	75	80	40	58	22 or 30

ISO size	A	B	C	D	E	F	G	J	K	M	N*
2	106	125	83	45	9	M6	55	48	24	38	22 or 30
3	138	140	83	45	14	M8	68	64	32	48	22 or 30
4	177	140	83	45	14	M8	75	80	40	58	22 or 30

\* Illustrated with 30 mm coil

\* Illustrated with 30 mm coil

-  Manual override
-  Model .../172
-  Model .../22, .../122

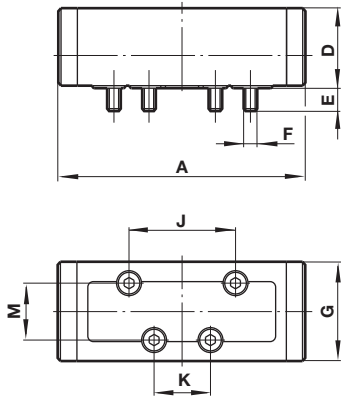
**5/2 and 5/3 Double air pilot valves**  
**ISO size 1, 2, 3 and 4**
**5**

ISO size	Model	A	D	E	F	G	J	K	M
1	All valves	107	32	9,5	M5	42,5	36	18	28
2	.../3, .../63	106	45	9	M6	55	48	24	38
3	.../3, .../63	138	45	14	M8	68	64	32	48
4	.../3, .../63	164	45	14	M8	75	80	40	58

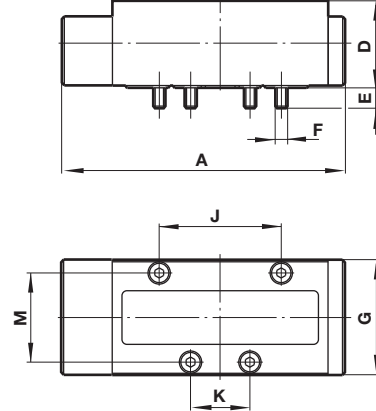
**5/2 Single air pilot valves**  
**ISO size 1, 2, 3 and 4**
**6**

ISO size	Model	A	D	E	F	G	J	K	M
2	.../40	124	45	9	M6	55	48	24	38
3	.../40	160	45	14	M8	68	64	32	48
4	.../40	187	45	14	M8	75	80	40	58

 Dimensions in mm  
 Projection/First angle

**Sub-bases and end plates**  
**VDMA 24345 sub-base options**  
**Single station sub-base side ported (Form A)**  
**for ISO G and NPT threads**

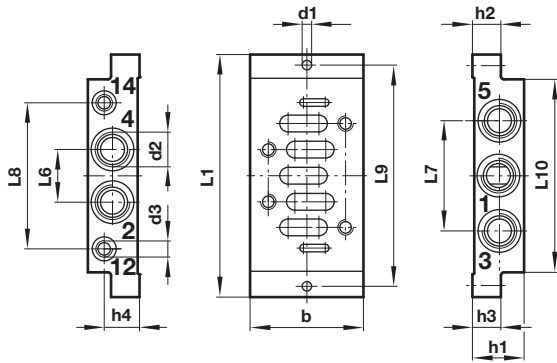

**Single station sub-base**  
**bottom ported (Form B)**  
**for ISO G and NPT threads**

Dimensions in mm  
Projection/First angle

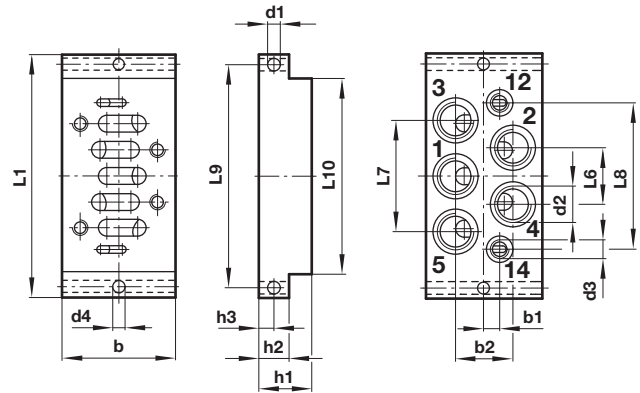

ISO size	b	d1	d2	d3	h1	h2	h3	Model
1	48	5,5	1/4"	1/8"	32	10	10,5 (21,5)	#/P19126
2	57	6,6	3/8"	1/8"	40	13	14 (26)	#/P19132
3	71	6,6	1/2"	1/8"	32	18		#/P19138
4	85	9	G3/4	G1/8	42	19	22	M/P19144

ISO size	b	b1	b2	d1	d2	d3	d4	h1	Model
1	46	7	23	5,5	1/4"	1/8"	5,5	30	#/P19125
2	56	8	27	6,6	3/8"	1/8"	6,6	35	#/P19131
3	71	10	34	6,6	1/2"	1/8"	6,6	32	#/P19137
4	85	15	40	9	G3/4	G1/8	9,5	28	M/P19143

ISO size	h4	L1	L6	L7	L8	L9	L10	kg	Model
1	23,5	110	24	43	58	98	84	0,16	#/P19126
2	30	124	30	56	74	112	95	0,28	#/P19132
3	22	149	32	68	90	136	119	0,36	#/P19138
4	30	186	42	90	111	170	148		M/P19144

ISO size	h2	h3	L1	L6	L7	L8	L9	L10	kg	Model
1	10	5	110	23	46	62	98	84	0,19	#/P19125
2	13	6,5	124	28	56	73	112	95	0,32	#/P19131
3	18	9	149	34	68	90	136	119	0,40	#/P19137
4	19	9	186	46	90	111	170	148		M/P19143

( ) Dimension for ports 3 and 5.  
# Insert 'M' for ISO G parallel or 'C' for NPT threads

**Modular sub-bases (Form C) and end plates (Form D)**  
**for ISO G and NPT threads**

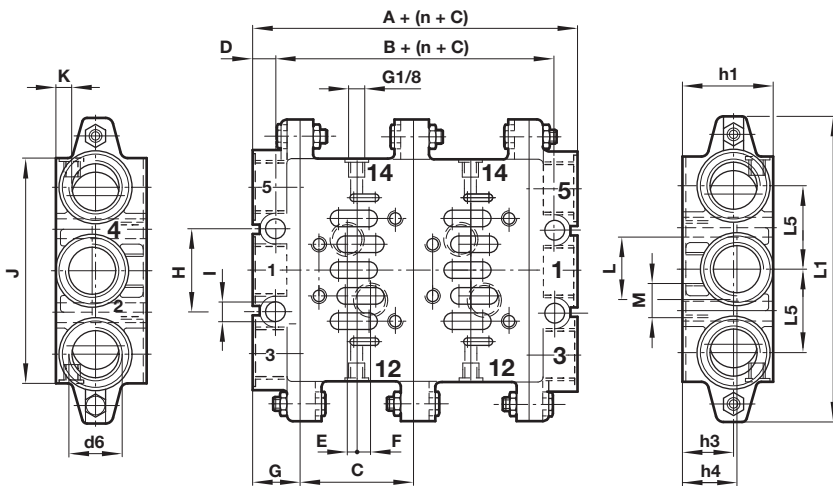

ISO size	A	B	C	D	E	F	G	H	I	kg	Model ISO G thread	Model NPT thread
1	44	22	43	11	1,5	7,5	22	28	7	0,24	CQM/22152/3/21	239-238B
2	52	26	56	13	5	6	26	35	9	0,36	CQM/22253/3/21	239-242B
3	60	30	71	15	6	8	30	52	12	0,72	CQM/22354/3/21	239-246B
4	60	30	82	15	8	9	30	56	12		CQM/22456/3/21	

ISO size	J	K	L	M	h1	h3	h4	L1	L5	d6	kg	Model ISO G thread	Model NPT thread
1	85	8,5	26	G1/4	46	21	24	110	28	3/8"	0,22	CQM/22152/3/22	239-289B
2	100	9	30	G3/8	47	22	24	135	28	1/2"	0,34	CQM/22253/3/22	239-291B
3	140	10	38	G1/2	56	31	34	190	52	1"	0,66	CQM/22354/3/22	239-293B
4	160	10	52	G1/2	58	30	30	215	54	1"		CQM/22456/3/22	

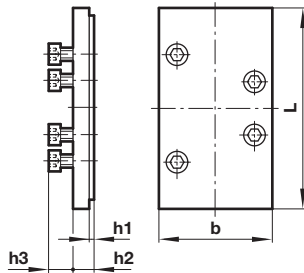

**Blanking plate for VDMA & universal sub-bases with ISO G and NPT threads**

ISO size	b	L	h1	h2	h3	kg	Model
1	42	80	2	14	11	0,05	CQM/22152/3/23
2	55	85	2,5	12,5	13,5	0,09	CQM/22253/3/23
3	70	120	2,5	12,5	15,5	0,26	CQM/22354/3/23
4	80	145	2,5	12,5	15,5	0,09	CQM/22456/3/23

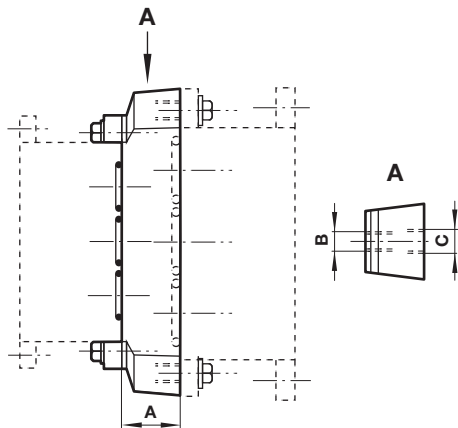
**Transition plate from ISO 1 » ISO 2, ISO 2 » ISO 3 and ISO 1 » ISO 3 for VDMA sub-bases for ISO G and NPT threads**

ISO size	A	B	C	kg	Model
1 » 2	25	M5	M6	0,35	CQM/22152/3/24
2 » 3	40	M6	M8	0,65	CQM/22253/3/24
1 » 3	34	M5	M8	0,90	FP8570

**Silencer for VDMA & universal sub-bases with ISO G and NPT threads**

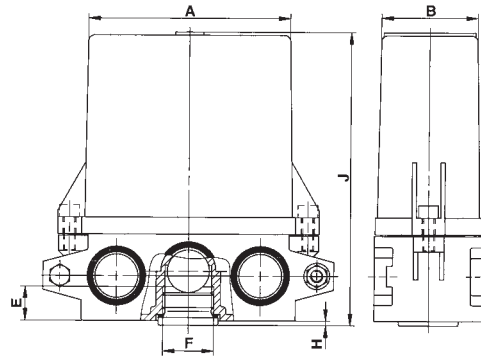
 Dimensions in mm  
 Projection/First angle

ISO size	A	B	E	F	H	J	Model
1	77	38	15	G3/8	2	122	0015510

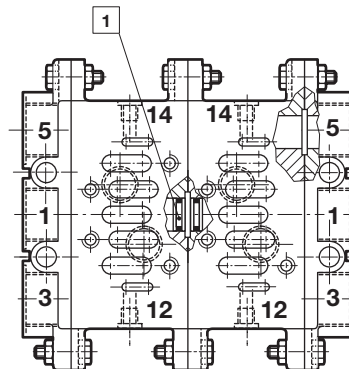
**Blanking disc FP8382, FP8482 & FP8582 for ISO G thread 239-251, 239-252 & 239-253 for NPT thread**

1 Blanking disc; FP8\*82 or 239-25\*

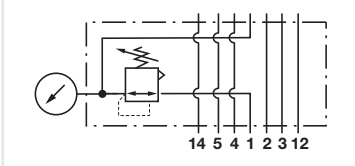
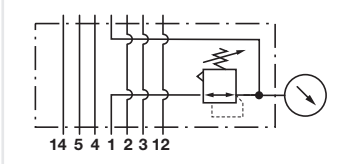

**Sandwich single pressure regulator plate with pressure regulator on port 1**

Symbol	ISO size	Regulator on side	Operation	Inlet pressure max. (bar)	Pressure range (bar)	Weight (kg)	Model
	1	14	Membrane pressure regulator with relieving valve	16	0,5 ... 12	0,6	V71010-KB1
	1	12	Membrane pressure regulator with relieving valve	16	0,5 ... 12	0,6	V71011-KB1

**Application:**

Pressure of port 1 can be regulated individually by using this intermediate plate.

**Note:**

Adjustment knob has push to lock feature.

**Sandwich single pressure regulator plate with pressure regulator on port 2 or port 4**

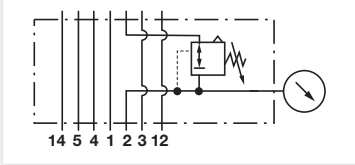
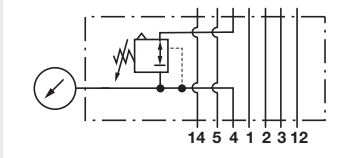
Symbol	ISO size	Regulated port	Operation	Inlet pressure max. (bar)	Pressure range (bar)	Weight (kg)	Model
	1	2	Membrane pressure regulator with relieving valve	16	0,5 ... 12	0,39	V71012-KB2
	1	4	Membrane pressure regulator with relieving valve	16	0,5 ... 12	0,39	V71012-KB3

**Application:**

Pressure of port 2 and 4 can be regulated individually by using this intermediate plate.

**Note:**

Adjustment knob has push to lock feature.

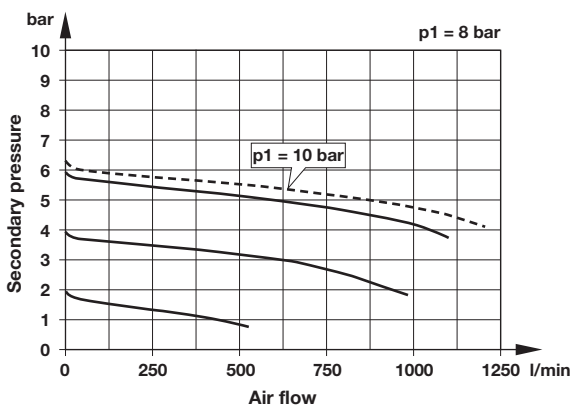
**Flow characteristics (inlet pressure: 8 bar)**

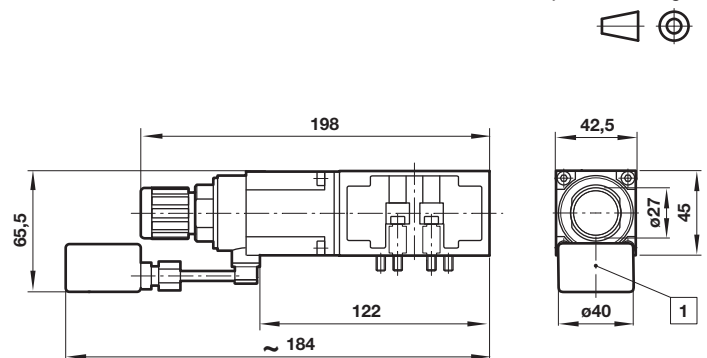
**Dimensions:**

 Dimensions in mm  
 Projection/First angle

1 Gauge

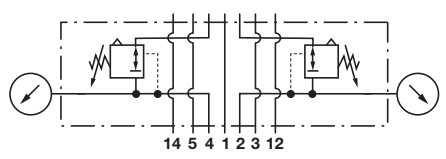
**Sandwich double pressure regulator plate with double pressure regulator on port 2 and 4**

Symbol	ISO size	Regulated port	Operation	Inlet pressure max. (bar)	Pressure range (bar)	Weight (kg)	Model
	1	2 and 4	Membrane pressure regulator with relieving valve	16	0,5 ... 12	0,39	V71012-KB4

**Application:**

Pressure of ports 2 and 4 can be regulated individually by using one of the intermediate plates.

**Note:**

Adjustment knob has push to lock feature.

**Flow characteristics (inlet pressure: 8 bar)**

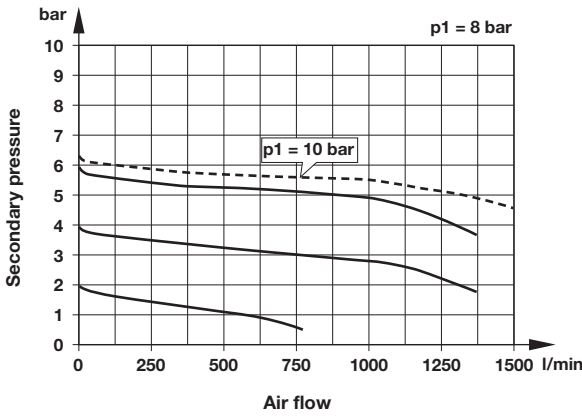

**Dimensions:**

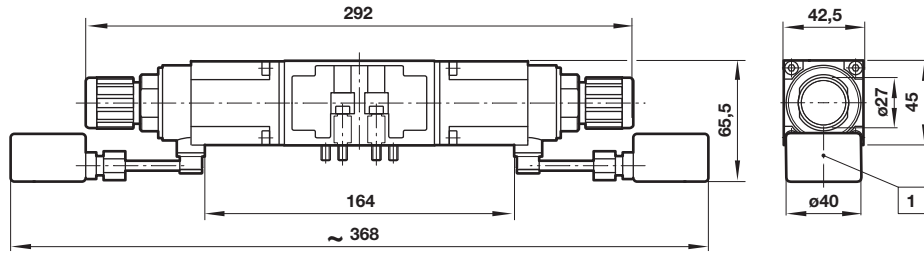

Dimensions in mm  
Projection/First angle



1 Gauge

**Sandwich plate with check valves**

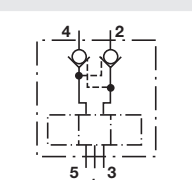
Symbol	ISO size	Design	Flow (l/min)	Operating pressure (bar)	Weight (kg)	Model
	1	Poppet valves	500	3 ... 8	0,45	FP7050
	3	Poppet valves	3400	3 ... 8	2,05	FP7070

**Application:**

With this type of intermediate plate together with a 5/3-way valve, center position open, a piston movement can be stopped in any desired position. This position will be kept during a long period.

**Note:**

Metal to metal sealed spool and sleeve valves have always a small amount of leak because of its design. Therefore 5/3-way valves, center position closed, are only applicable for short stops.

**Caution: Not suitable for safety applications!**

**Dimensions:**

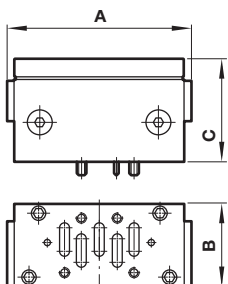

ISO	A	B	C	Model
1	96	42	52	FP7050
3	165	62	95	FP7070

### Flow regulator plate

Symbol	ISO size	Regulated port	Operation	Inlet pressure max. (bar)	Model
	1	3 and 5	Piston regulator	-0,9 ... 16	CQM/22152/3/26
	2	3 and 5			CQM/22253/3/26
	3	3 and 5	Piston regulator	-0,9 ... 16	CQM/22354/3/26
	4	3 and 5			CQM/22456/3/26

Application:  
Regulation of exhaust ports 3 and 5 allows easy cylinder speed control

Note:  
The regulator screw can be locked with the lock nut.

### Flow charakteristik (inlet pressure: 8 bar)

#### ISO 1

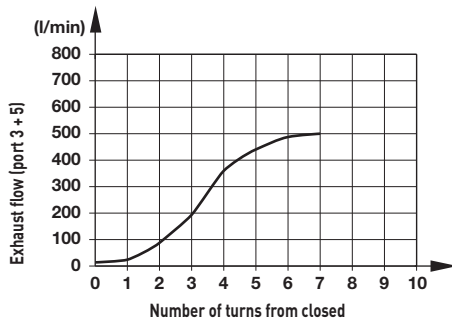

#### ISO 2

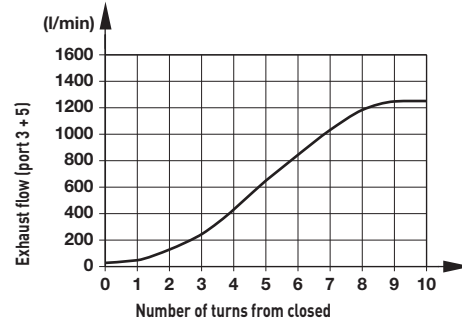

#### ISO 3

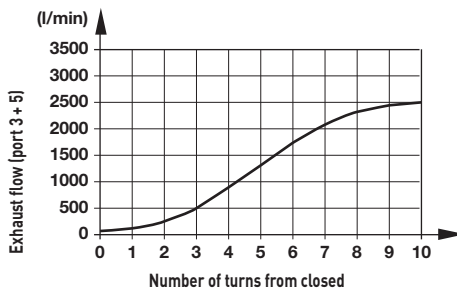

#### ISO 4

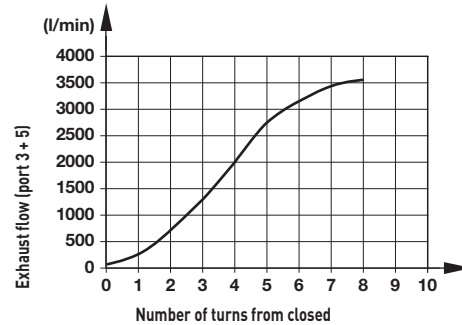

### Dimensions

Dimensions in mm  
Projection/First angle

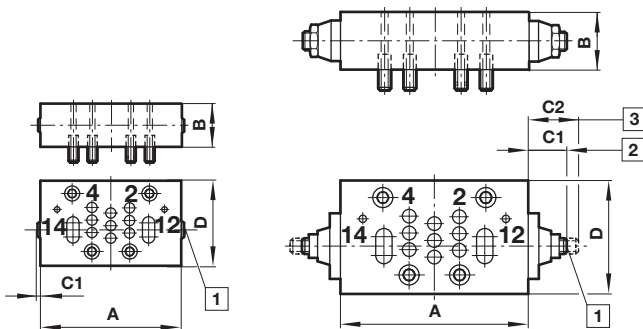

ISO	A	B	C1	C2	D	kg	Model
1	112,5	16	1,5	-	38	0,20	CQM/22152/3/26
2	124,5	19	2		51	0,35	CQM/22253/3/26
3	141	25	18,5	29	63,5	0,86	CQM/22354/3/26
4	196	25	19	31	76	1,10	CQM/22456/3/26

- 1 Regulating screw
- 2 Closed
- 3 Open

### Warning

These products are intended for use in industrial compressed air systems only. Do not use these products where pressures and temperatures can exceed those listed under »Technical features/data«.

Before using these products with fluids other than those specified, for non-industrial applications, life-support systems or other applications not within published specifications, consult IMI NORGREN.

Through misuse, age, or malfunction, components used in fluid power systems can fail in various modes.

The system designer is warned to consider the failure modes of all component parts used in fluid power systems and to provide adequate safeguards to prevent personal injury or damage to equipment in the event of such failure.

System designers must provide a warning to end users in the system instructional manual if protection against a failure mode cannot be adequately provided.

System designers and end users are cautioned to review specific warnings found in instruction sheets packed and shipped with these products.